



PACKAGE GAS / ELECTRIC ROOFTOP UNITS

FORM NO. EXR11-847

Featuring Industry Standard R-410A Refrigerant

R-410A

SKKL-B HIGH EFFICIENCY SERIES
NOMINAL SIZES 7.5, 10 & 12.5 TON [26.4, 35.2 & 44.0 kW]
ASHRAE 90.1-2010 COMPLIANT MODELS

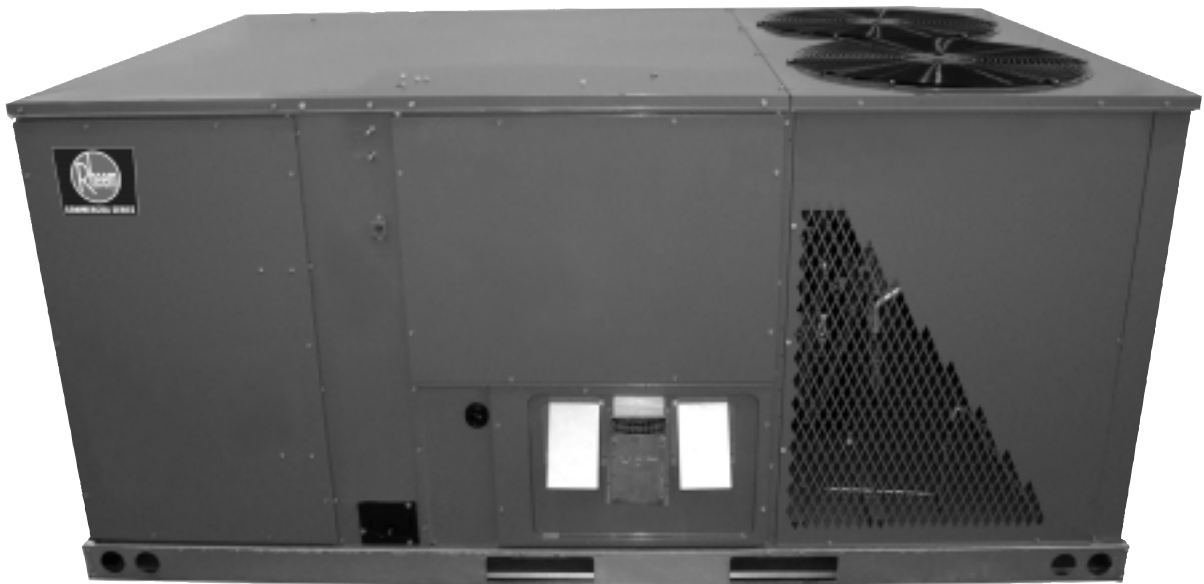

Unit shown with optional
louvered coil protection.



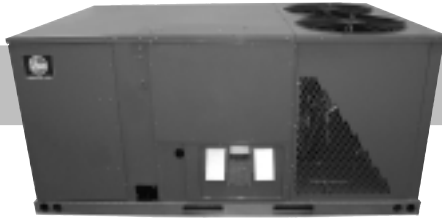

Introduction	3
Unit Features & Benefits	4-7
Selection Procedure	8
Model Identification Options	9-10
General Data	
SKKL- Series	11-15
General Data Notes	16
Performance Data	
SKKL- Series	17-19
Airflow Performance	
SKKL- Series	20-22
Electrical Data	
SKKL- Series	23
Dimensional Data	24-27
Accessories	28-46
Mechanical Specifications	47-53
Typical Wiring	54-59

These quality features are included in the Rheem Package Gas/Electric Unit

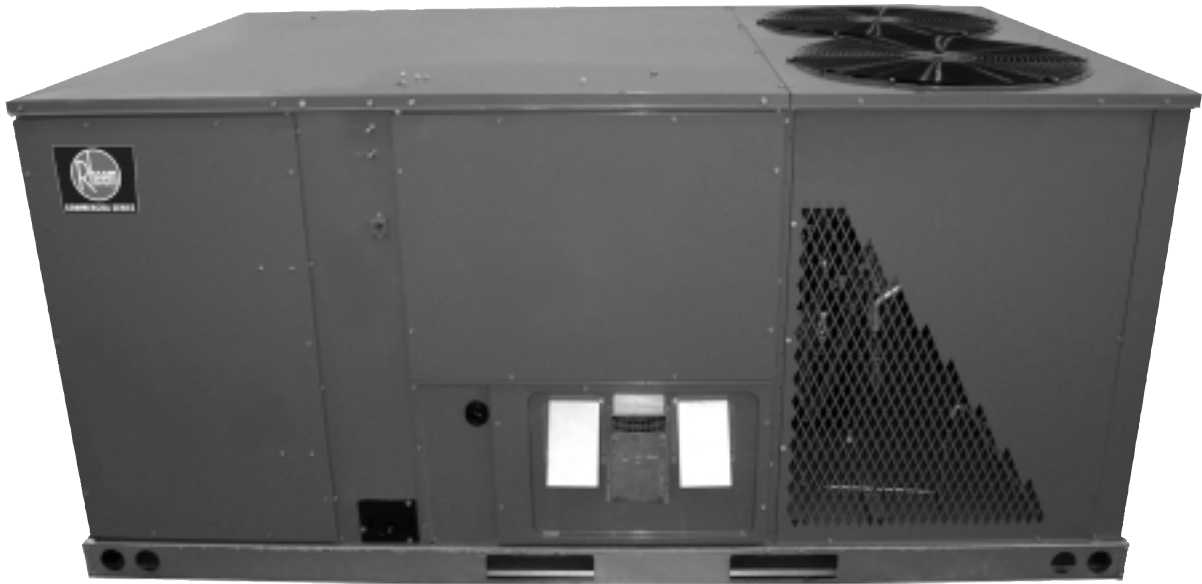

STANDARD FEATURES INCLUDE:

- R-410A HFC refrigerant.
- Complete factory charged, wired and run tested.
- Scroll compressors with internal line break overload and high-pressure protection.
- Single stage compressor on 7.5 and 10 Ton models.
- Two stage cooling on 12.5 ton model.
- Convertible airflow.
- Fixed restriction refrigerant flow control on 7.5 and 10 ton models.
- TXV refrigerant flow control on 12.5 ton.
- High Pressure and Low Pressure/Loss of charge protection standard on all models.
- Solid Core liquid line filter drier on each circuit.
- Single slab, single pass designed evaporator and condenser coils facilitate easy cleaning for maintained high efficiencies.
- Cooling operation up to 125 degree F ambient.
- MicroChannel Outdoor Coils.
- Foil faced insulation encapsulated throughout entire unit minimizes airborne fibers from the air stream.
- Access door with heavy-duty gasketing, and mechanically attached with 5/16" screws.
- Slide Out Indoor fan assembly for added service convenience.
- Powder Paint Finish meets ASTM B117 steel coated on each side for maximum protection. G90 galvanized.
- One piece top cover and one piece base pan with drawn supply and return opening for superior water management.
- Forkable base rails for easy handling and lifting.
- Single point electrical and gas connections.
- Internally sloped slide out condensate pan conforms to ASHRAE 62 standards.
- High performance belt drive motor with variable pitch pulleys and quick adjust belt system.
- Permanently lubricated evaporator, condenser and gas heat inducer motors.
- Condenser motors are internally protected, totally enclosed with shaft down design.
- 2 inch filter standard with slide out design.
- Two stage gas valve, direct spark ignition, and induced draft for efficiency and reliability.
- Tubular heat exchange for long life and induced draft for efficiency and reliability.
- Solid state furnace control with on board diagnostics.
- 24 volt control system with resettable circuit breakers.
- Colored and labeled wiring.
- Copper tube/Aluminum Fin Evaporator coil.
- Molded compressor plug.

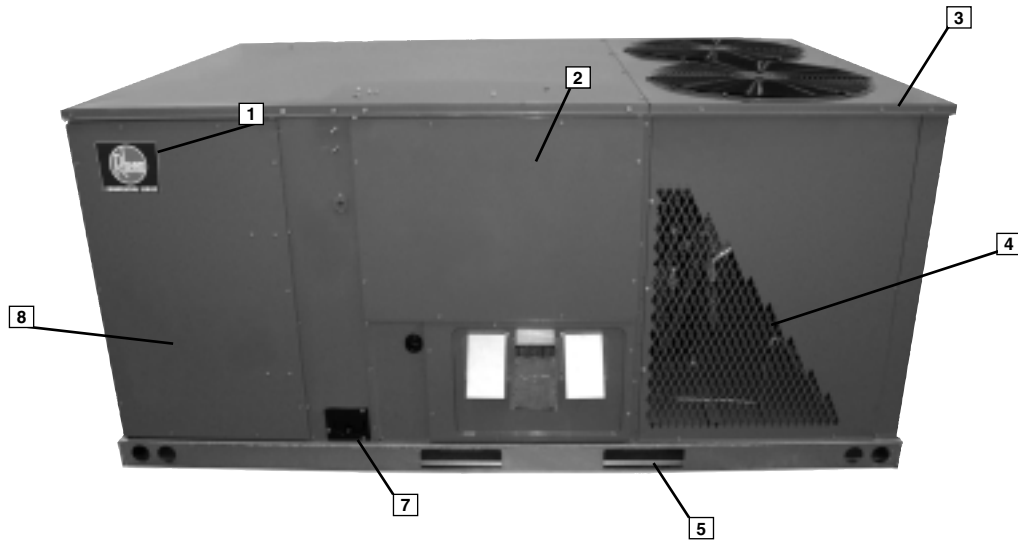

Rheem Package equipment is designed from the ground up with the latest features and benefits required to compete in today's market. The clean design stands alone in the industry and is a testament to the quality, reliability, ease of installation and serviceability that goes into each unit. Outwardly, the large Rheem *Commercial Series*[™] label (1) identifies the brand to the customer.

The sheet-metal cabinet (2) uses nothing less than 18-gauge material for structural components with an underlying coat of G90. To ensure the leak-proof integrity of these units, the design utilizes a one-piece top with a 1/8" drip lip (3), gasket-protected panels and screws. The Rheem hail guard (4) (optional) is its trademark, and sets the standard for coil protection in the industry. Every Rheem package unit uses the toughest finish in the industry, using electro deposition baked-on enamel tested to withstand a rigorous 1000-hour salt spray test, per ASTM B117.

Anything built to last must start with the right foundation. In this case, the foundation is 14-gauge, commercial-grade, full-perimeter base rails (5), which integrate fork slots and rigging holes to save set-up time on the job site. The base pan is stamped, which forms a 1-1/8" flange around the supply and return opening and has eliminated the worry of water entering the conditioned space (6). The drainpan (7) is made of material that resists the growth of harmful bacteria and is sloped for the latest IAQ benefits. Furthermore, the drain pan slides out for easy cleaning. The insulation has been placed on the underside of the basepan, removing areas that would allow for potential moisture accumulation, which can facilitate growth of harmful bacteria. All insulation is secured with both adhesive and mechanical fasteners, and all edges are hidden.

During development, each unit was tested to U.L. 1995, ANSI 21.47, AHRI 340-360 and other Rheem-required reliability tests. Rheem adheres to stringent ISO 9002 quality procedures, and each unit bears the U.L. and AHRI certification labels located on the unit nameplate (8). Contractors can rest assured that when a Rheem package unit arrives at the job, it is ready to go with a factory charge and quality checks. Each unit also proudly displays the "Made in the USA" designation.

Access is granted with mechanical fasteners. Access to all major compartments is from the front of the unit, including the filter and electrical compartment, blower compartment, furnace section, and outdoor section. Each panel is permanently embossed with the compartment name (control/filter access, blower access and furnace access).

Electrical and filter compartment access is through a large access panel. The unit charging chart is located on the inside of the electrical and filter compartment door. Electrical wiring diagrams are found on the control box cover, which allows contractors to move them to more readable locations. To the right of the control box the model and serial number can be found. Having this information on the inside will assure model identification for the life of the product. The production line quality test assurance label is also placed in this location (9). The two-inch throwaway filters (10) are easily removed on a tracked system for easy replacement.

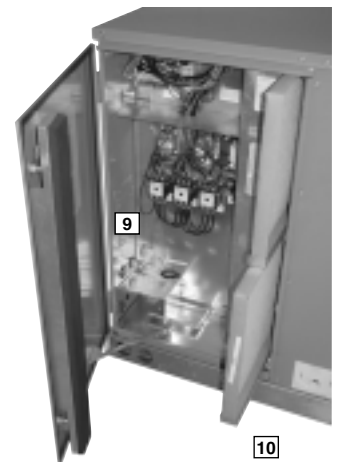
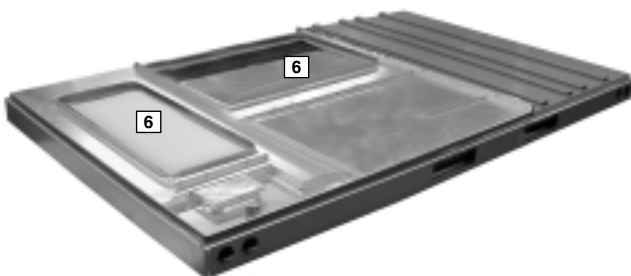

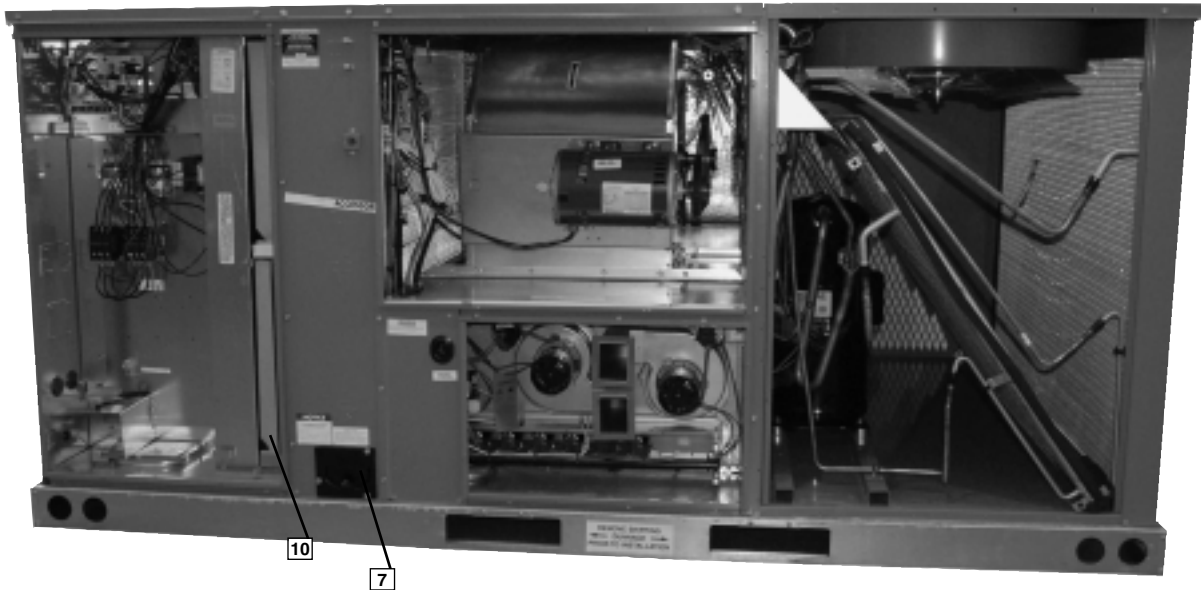

Inside the control box (11), each electrical component is clearly identified with a label that matches the component to the wire diagram for ease of troubleshooting. All wiring is numbered on each end of the termination and color-coded to match the wiring diagram. The integrated furnace control, used to control furnace operation, incorporates a flashing LED troubleshooting device. Flash codes are clearly outlined on the unit wiring diagram. The control transformer has a low voltage circuit breaker that trips if a low voltage electrical short occurs. There is a blower contactor and compressor contactor for each compressor.



For added convenience in the field, a factory-installed convenience outlet and non-fused disconnect (12) are available. Low and High voltage can enter either from the side or through the base. Low-voltage connections are made through the low-voltage terminal strip. For ease of access, the U.L.-required low voltage barrier can be temporarily removed for low-voltage termination and then reinstalled. The high-voltage connection is terminated at the number 1 compressor contactor. The suggested mounting for the field-installed disconnect is on the exterior side of the electrical control box.



To the right of the electrical and filter compartment are the externally mounted gauge ports, which are permanently identified by embossed wording that clearly identifies the compressor circuit, high pressure connection and low pressure connection (13). With the gauge ports mounted externally, an



accurate diagnostic of system operation can be performed quickly and easily. Brass caps on the schrader fitting assure that the gauge parts are leak proof.

The blower compartment is to the right of the gauge ports and can be accessed by mechanical fastener. To allow easy maintenance of the blower assembly, the entire assembly easily slides out by removing two 3/8" screws from the blower retention bracket. The adjustable motor pulley (14) can easily be adjusted by loosening the bolts on either side of the motor mount. Removing the bolts allows for easy removal of the blower pulley by pushing the blower assembly up to loosen the belt. Once the belt is removed, the motor sheave can be adjusted to the desired number of turns, ranging from 0 to 6 turns open. Where the demands for the job require high static, Rheem has high-static drives available that deliver nominal airflow up to 2" of static. By referring to the airflow performance tables listed in the installation instructions, proper static pressure and CFM requirements can be dialed in. The scroll housing (15) and blower scroll provide quiet and efficient airflow.

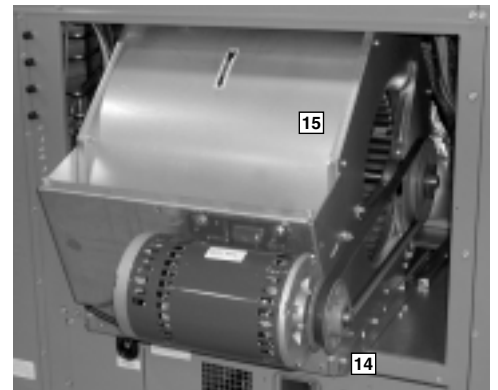

The blower sheave is secured by an "H" bushing which firmly secures the pulley to the blower shaft for years of trouble-free operation. The "H" bushing allows for easy removal of the blower pulley from the shaft, as opposed to the use of a set screw, which can score the shaft, creating burrs that make blower-pulley removal difficult.

Also inside the blower compartment is the low-ambient control (16), low-pressure switch (17), high-pressure switch (18) and freeze stat (opt.) refrigerant safety device (19). The low-ambient control allows for operation of the compressor down to 0 degrees ambient temperature by cycling the outdoor fans on high pressure. The high-pressure switch will shut off the compressors if pressures in excess of 610 PSIG are detected, this may occur if the outdoor fan motor fails. The low-pressure switch shuts off the compressors if low pressure is detected due to loss of charge. The freeze stat protects the compressor if the evaporator coil gets too cold (below freezing) due to low air-flow. Each factory-installed option is brazed into the appropriate high or low side and wired appropriately. Use of polarized plugs and sharder fittings allow for easy field installation.

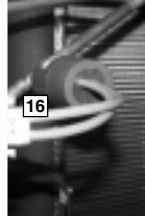
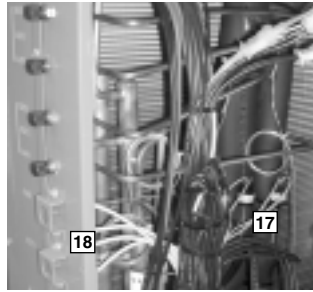

Inside the blower compartment the interlaced evaporator can also be viewed. The evaporator uses enhanced fin technology for maximum heat transfer. Precise metering devices assure even distribution of refrigerant throughout the evaporator. MicroChannel technology is used on outdoor coil.

Wiring throughout the unit is neatly bundled and routed. Where wire harnesses go through the condenser bulkhead or blower deck, a molded wire harness assembly (20) provides an air-tight and water-tight seal, and provides strain relief. Care is also taken to tuck raw edges of insulation behind sheet metal to improve indoor air quality.

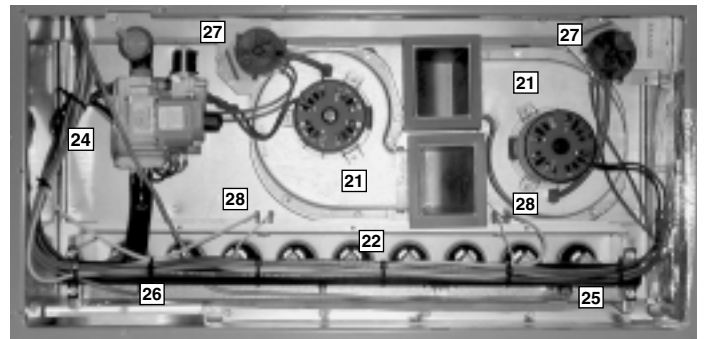
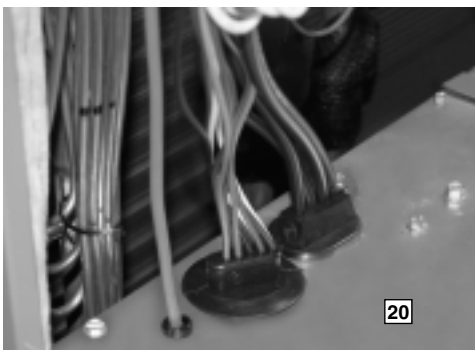

The furnace compartment contains the latest furnace technology on the market. The draft inducers (21) draw the flame from the Rheem exclusive in-shot burners (22) into the aluminized tubular heat exchanger (23) for clean, efficient gas heat. Stainless steel heat exchangers can be factory installed for those applications that have high fresh-air requirements, or applications in corrosive environments. Each furnace is equipment with a two-stage gas valve (24), which provides two stages of gas heat input. The first stage operates at 50% of the second stage (full fire). 81% steady state efficiency is maintained on both first and second stage by staging the multiple inducers to optimize the combustion airflow and maintain a near stioceometric burn at each stage.

The direct spark igniter (25) assures reliable ignition in the most adverse conditions. This is coupled with remote flame sense (26) to assure that the flame has carried across the entire length of the burner assembly. Gas supply can be routed from the side or up through the base.

Each furnace has the following safety devices to assure consistent and reliable operation after ignition:

- Pressures switches (27) to assure adequate combustion airflow before ignition.
- Rollout switches (28) to assure no obstruction or cracks in the heat exchanger.
- A limit device that protects the furnace from over-temperature problems.

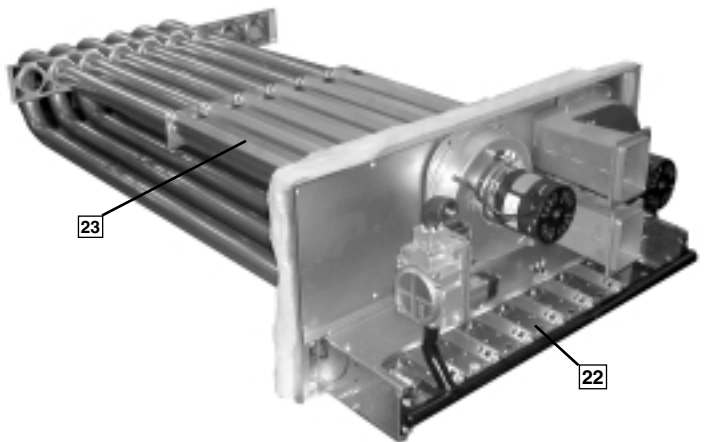



UNIT FEATURES & BENEFITS—SKKL- SERIES

The compressor compartment houses the heart-beat of the unit. The scroll compressor (29) is known for its long life, and for reliable, quiet, and efficient operation. The suction and discharge lines are designed with shock loops (30) to absorb the strain and stress that the starting torque, steady state operation, and shut down cycle impose on the refrigerant tubing.

Each unit comes standard with filter dryer (31). The condenser fan motor (32) can easily be accessed and maintained through the blower compartment. The polarized plug connection allows the motor to be changed quickly and eliminates the need to snake wires through the unit.

The outdoor coil uses the latest micro channel technology (33) for the most effective method of heat transfer. The outdoor coil is protected by optional louvered panels, which allow unobstructed airflow while protecting the unit from both Mother Nature and vandalism.

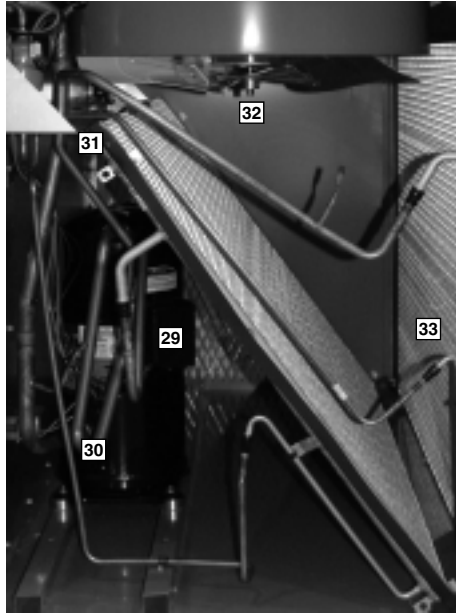

Each unit is designed for both downflow or horizontal applications (34) for job configuration flexibility. The return air compartment can also contain an economizer (35). Two models exist, one for downflow applications, and one for horizontal applications. Each unit is pre-wired for the economizer to allow quick plug-in installation. The economizer is also available as a factory-installed option. The economizer, which provides free cooling when outdoor conditions are suitable and also provides fresh air to meet local requirements, comes standard with single enthalpy controls. The controls can be upgraded to dual enthalpy easily in the field. The direct drive actuator combined with gear drive dampers has eliminated the need for linkage adjustment in the field. The economizer control has a minimum position setpoint, an outdoor-air setpoint, a mix-air setpoint, and a CO² setpoint. Barometric relief is standard on all economizers. The power exhaust is housed in the barometric relief opening and is easily slipped in with a plug-in assembly. The wire harness to the economizer also has accommodations for a smoke detector.

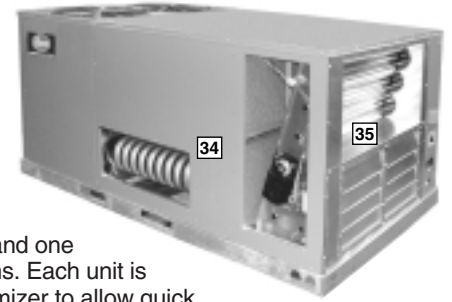

The Rheem roofcurb (36) is made for toolless assembly at the jobsite by engaging a pin into the hinged corners of adjacent curb sides, which makes the assembly process quick and easy.

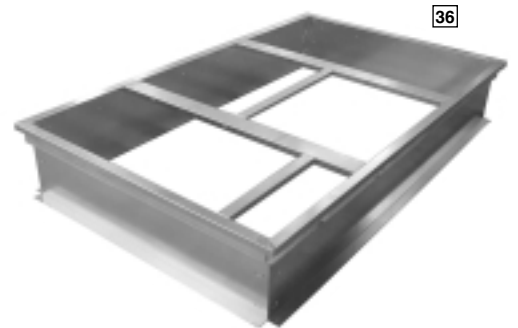



To select an SKKL-B Cooling and Heating unit to meet a job requirement, follow this procedure, with example, using data supplied in this specification sheet.

1. DETERMINE COOLING AND HEATING REQUIREMENTS AND SPECIFIC OPERATING CONDITIONS FROM PLANS AND SPECS.

Example:

Voltage —	380/415V—3 Phase—50 Hz
Total Cooling Capacity —	89,000 BTUH [26.1 kW]
Sensible Cooling Capacity —	67,000 BTUH [19.6 kW]
Heating Capacity —	145,000 BTUH [42.5 kW]
*Condenser Entering Air —	95 °F [35.0 °C] DB
*Evaporator Mixed Air Entering —	65 °F [18.3 °C] WB 78 °F [25.6 °C] DB
*Indoor Air Flow (vertical) —	3000 CFM [1416 L/s]
*External Static Pressure —	0.40 in. WG [.10 kPa]

2. SELECT UNIT TO MEET COOLING REQUIREMENTS.

Since total cooling is within the range of a nominal 10 ton [35.1 kW] unit, enter cooling performance table at 95°F [35.0 °C] DB condenser inlet air. Interpolate between 63°F [17.2 °C] WB and 67°F [19.4 °C] WB to determine total and sensible capacity and power input for 65°F [18.3 °C] WB evaporator inlet air at 3000 CFM [1416 L/s] indoor air flow (table basis):

Total Cooling Capacity = 101,450 BTUH [29.71 kW]
Sensible Cooling Capacity = 82,550 BTUH [24.17 kW]
Power Input (Compressor and Cond. Fans) = 7,600 watts

Use formula in note (1) to determine sensible capacity at 78°F [25.6 °C] DB evaporator entering air:

$82,550 + (1.10 \times 3,000 \times (1 - 0.05) \times (78 - 80))$
Sensible Cooling Capacity = 76,280 BTUH [22.34 kW]

3. CORRECT CAPACITIES OF STEP 2 FOR ACTUAL AIR FLOW.

Select factors from airflow correction table at 3000 CFM [1416 L/s] and apply to data obtained in step 2 to obtain gross capacity:

Total Capacity = $101,450 \times 0.97 = 98,407$ BTUH [28.81 kW]
Sensible Capacity = $76,280 \times 0.93 = 70,940$ BTUH [20.77 kW]
Power Input = $7,600 \times 0.99 = 7,524$ Watts

These are Gross Capacities, not corrected for blower motor heat or power.

4. DETERMINE BLOWER SPEED AND WATTS TO MEET SYSTEM DESIGN.

Enter Indoor Blower performance table at 3000 CFM [1416 L/s]. Total ESP (external static pressure) per the spec of 0.40 in. WG [.10 kPa] includes the system duct and grilles. Add from the table “Component Air Resistance”, 0.06 in. WG [.01 kPa] for wet coil, 0 in. WG [.00 kPa] for downflow air flow, for a total selection static pressure of 0.46 (0.5) in. WG [.12 kPa], and determine:

RPM = 706
WATTS = 1,127
DRIVE = L (standard 3 H.P. motor)

5. CALCULATE INDOOR BLOWER BTUH HEAT EFFECT FROM MOTOR WATTS, STEP 4.

$$1,127 \times 3.412 = 3,845 \text{ BTUH [1.13 kW]}$$

6. CALCULATE NET COOLING CAPACITIES, EQUAL TO GROSS CAPACITY, STEP 3, MINUS INDOOR BLOWER MOTOR HEAT.

$$\text{Net Total Capacity} = 98,407 - 3,845 = 94,562 \text{ BTUH [27.69 kW]}$$

$$\text{Net Sensible Capacity} = 70,940 - 3,845 = 67,095 \text{ BTUH [19.65 kW]}$$

7. CALCULATE UNIT INPUT AND JOB EER.

$$\text{Total Power Input} = 7,524 \text{ (step 3)} + 1,127 \text{ (step 4)} = 8,651 \text{ Watts}$$

$$\text{EER} = \frac{\text{Net Total BTUH [kW] (step 6)}}{\text{Power Input, Watts (above)}} = \frac{94,562}{8,651} = 10.93$$

8. SELECT UNIT HEATING CAPACITY.

From Physical Data Table read that gas heating output (input rating x efficiency) is:

$$\text{Heating Capacity} = 145,800 \text{ BTUH [42.7 kW]}$$

9. CHOOSE MODEL SKKL-B120NL18E

*NOTE: These operating conditions are typical of a commercial application in a 95°F/79°F [35°C/26°C] design area with indoor design of 76°F [24°C] DB and 50% RH and 10% ventilation air, with the unit roof mounted and centered on the zone it conditions by ducts.

[] Designates Metric Conversions



MODEL IDENTIFICATION—SKKL- SERIES

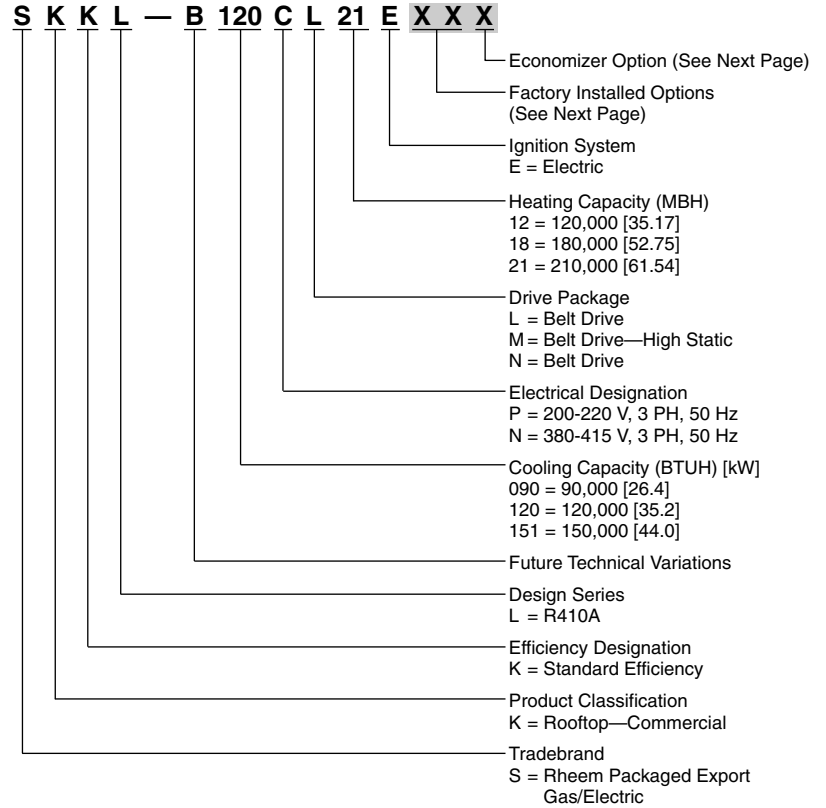

[] Designates Metric Conversions



FACTORY INSTALLED OPTION CODES FOR SKKL (B090 to B151) 7.5, 10 & 12.5 TON [26.4, 35.2 & 44.0 kW]

Option Code	Hail Guard	Stainless Steel Heat Exchanger	Non-Powered Convenience Outlet/Unfused Service Disconnect	Low Ambient/ Freeze Stat
AD	x			
AJ		x		
AH			x	
AP				x
BF	x		x	
BG	x	x		
BY	x			x
JB		x	x	
CR	x	x		x
DN	x	x	x	x

ECONOMIZER SELECTION FOR SKKL (B090 to B151) 7.5, 10 & 12.5 TON [26.4, 35.2 & 44.0 kW]

Option Code	No Economizer	Single Enthalpy Economizer w/Barometric Relief	Single Enthalpy Economizer w/Barometric Relief and Smoke Detector
A	x		
B		x	
C			x

“x” indicates factory installed option.

Instructions for Factory Installed Option(s) Selection

Note: Three characters following the model number will be utilized to designate a factory-installed option or combination of options. If no factory option(s) is required, nothing follows the model number.

Step 1. After a basic rooftop model is selected, choose a *two-character* option code from the FACTORY INSTALLED OPTION SELECTION TABLE.

Proceed to Step 2.

Step 2. The last option code character is utilized for factory-installed economizers. Choose a character from the FACTORY INSTALLED ECONOMIZER SELECTION TABLE.

Examples:

SKKL-B120CL22E.....this unit has no factory installed options.

SKKL-B120CL22E**BGA**.....this unit is equipped with *hail guard and stainless steel heat exchanger*.

SKKL-B120CL22E**AHA**.....this unit is equipped with a *non-powered convenience outlet and service disconnect*.

SKKL-B120CL22E**AHB**.....this unit is equipped as above and includes an *Economizer with single enthalpy sensor and with barometric relief*.

SKKL-B120CL22E**AAB**.....this unit is equipped with an *Economizer with single enthalpy sensor and Barometric Relief*.

[] Designates Metric Conversions



NOM. SIZES 7.5 TON [26.4 kW] ASHRAE 90.1-2007 COMPLIANT MODELS

Model SKKL- Series	B090NL12E	B090NL18E	B090NM12E	B090NM18E
Cooling Performance¹				CONTINUED →
Gross Cooling Capacity Btu [kW]	74,000 [21.68]	74,000 [21.68]	74,000 [21.68]	74,000 [21.68]
EER/SEER ²	11.6/NA	11.6/NA	11.6/NA	11.6/NA
Rated CFM [L/s]	2400 [1133]	2400 [1133]	2400 [1133]	2400 [1133]
Net Cooling Capacity Btu [kW]	72,000 [21.1]	72,000 [21.1]	72,000 [21.1]	72,000 [21.1]
Net Sensible Capacity Btu [kW]	55,000 [16.11]	55,000 [16.11]	55,000 [16.11]	55,000 [16.11]
Net Latent Capacity Btu [kW]	17,000 [4.98]	17,000 [4.98]	17,000 [4.98]	17,000 [4.98]
IEER ³	11.8	11.8	11.8	11.8
Net System Power kW	6.18	6.18	6.18	6.18
Heating Performance (Gas)⁴				
Heating Input Btu [kW] (1st Stage / 2nd Stage)	60,000/120,000 [17.58/35.16]	90,000/180,000 [26.37/52.74]	60,000/120,000 [17.58/35.16]	90,000/180,000 [26.37/52.74]
Heating Output Btu [kW] (1st Stage / 2nd Stage)	48,600/97,200 [14.24/28.48]	72,900/145,800 [21.36/42.72]	48,600/97,200 [14.24/28.48]	72,900/145,800 [21.36/42.72]
Temperature Rise Range °F [°C] (1st Stage / 2nd Stage)	25-55 [13.9-30.6] / 25-55 [13.9-30.6]	40-70 [22.2-38.9] / 40-70 [22.2-38.9]	25-55 [13.9-30.6] / 25-55 [13.9-30.6]	40-70 [22.2-38.9] / 40-70 [22.2-38.9]
Steady State Efficiency (%)	81	81	81	81
No. Burners	6	9	6	9
No. Stages	2	2	2	2
Gas Connection Pipe Size in. [mm]	0.5 [12.7]	0.75 [19]	0.5 [12.7]	0.75 [19]
Compressor				
No./Type	1/Scroll	1/Scroll	1/Scroll	1/Scroll
Outdoor Sound Rating (dB)⁵				
	88	88	88	88
Outdoor Coil—Fin Type				
Tube Type	Louvered	Louvered	Louvered	Louvered
MicroChannel Depth in. [mm]	1 [25.4]	1 [25.4]	1 [25.4]	1 [25.4]
Face Area sq. ft. [sq. m]	13.5 [1.25]	13.5 [1.25]	13.5 [1.25]	13.5 [1.25]
Rows / FPI [FPcm]	1 / 23 [9]	1 / 23 [9]	1 / 23 [9]	1 / 23 [9]
Indoor Coil—Fin Type				
Tube Type	Louvered	Louvered	Louvered	Louvered
Tube Size in. [mm]	Rifled	Rifled	Rifled	Rifled
Face Area sq. ft. [sq. m]	0.375 [9.5]	0.375 [9.5]	0.375 [9.5]	0.375 [9.5]
Rows / FPI [FPcm]	13.5 [1.25]	13.5 [1.25]	13.5 [1.25]	13.5 [1.25]
Refrigerant Control	2 / 18 [7]	2 / 18 [7]	2 / 18 [7]	2 / 18 [7]
Drain Connection No./Size in. [mm]	Orifices	Orifices	Orifices	Orifices
	1/1 [25.4]	1/1 [25.4]	1/1 [25.4]	1/1 [25.4]
Outdoor Fan—Type				
No. Used/Diameter in. [mm]	Propeller	Propeller	Propeller	Propeller
Drive Type/No. Speeds	1/24 [609.6]	1/24 [609.6]	1/24 [609.6]	1/24 [609.6]
CFM [L/s]	Direct/1	Direct/1	Direct/1	Direct/1
No. Motors/HP	3749 [1769]	3749 [1769]	3749 [1769]	3749 [1769]
Motor RPM	1 at 1/2 HP	1 at 1/2 HP	1 at 1/2 HP	1 at 1/2 HP
	895	895	895	895
Indoor Fan—Type				
No. Used/Diameter in. [mm]	FC Centrifugal	FC Centrifugal	FC Centrifugal	FC Centrifugal
Drive Type/No. Speeds	1/15x15 [381x381]	1/15x15 [381x381]	1/15x15 [381x381]	1/15x15 [381x381]
No. Motors	Belt/Variable	Belt/Variable	Belt/Variable	Belt/Variable
Motor HP	1	1	1	1
Motor RPM	3	3	3	3
Motor Frame Size	1440	1440	1440	1440
	56	56	56	56
Filter—Type				
Furnished	Disposable	Disposable	Disposable	Disposable
(No.) Size Recommended in. [mm x mm x mm]	Yes	Yes	Yes	Yes
	(6)2x18x18 [51x457x457]	(6)2x18x18 [51x457x457]	(6)2x18x18 [51x457x457]	(6)2x18x18 [51x457x457]
Refrigerant Charge Oz. [g]				
	113.6 [3221]	113.6 [3221]	113.6 [3221]	113.6 [3221]
Weights				
Net Weight lbs. [kg]	890 [404]	926 [420]	890 [404]	926 [420]
Ship Weight lbs. [kg]	927 [420]	963 [437]	927 [420]	963 [437]

See Page 16 for Notes.

[] Designates Metric Conversions



NOM. SIZES 7.5 TON [26.4 kW] & 10 TON [35.2 kW] ASHRAE 90.1-2007 COMPLIANT MODELS

Model SKKL- Series	B090PL12E	B090PL18E	B120NL12E	B120NL18E
Cooling Performance¹				
Gross Cooling Capacity Btu [kW]	74,000 [21.68]	74,000 [21.68]	104,000 [30.47]	104,000 [30.47]
EER/SEER ²	11.6/NA	11.6/NA	11.2/NA	11.2/NA
Rated CFM [L/s]	2400 [1133]	2400 [1133]	3000 [1416]	3000 [1416]
Net Cooling Capacity Btu [kW]	72,000 [21.1]	72,000 [21.1]	100,000 [29.3]	100,000 [29.3]
Net Sensible Capacity Btu [kW]	55,000 [16.11]	55,000 [16.11]	72,700 [21.3]	72,700 [21.3]
Net Latent Capacity Btu [kW]	17,000 [4.98]	17,000 [4.98]	27,300 [8]	27,300 [8]
IEER ³	11.8	11.8	11.9	11.9
Net System Power kW	6.18	6.18	8.86	8.86
Heating Performance (Gas)⁴				
Heating Input Btu [kW] (1st Stage / 2nd Stage)	60,000/120,000 [17.58/35.16]	90,000/180,000 [26.37/52.74]	60,000/120,000 [17.58/35.16]	90,000/180,000 [26.37/52.74]
Heating Output Btu [kW] (1st Stage / 2nd Stage)	48,600/97,200 [14.24/28.48]	72,900/145,800 [21.36/42.72]	48,600/97,200 [14.24/28.48]	72,900/145,800 [21.36/42.72]
Temperature Rise Range °F [°C] (1st Stage / 2nd Stage)	25-55 [13.9-30.6] / 25-55 [13.9-30.6]	40-70 [22.2-38.9] / 40-70 [22.2-38.9]	15-45 [8.3-25] / 15-45 [8.3-25]	25-55 [13.9-30.6] / 25-55 [13.9-30.6]
Steady State Efficiency (%)	81	81	81	81
No. Burners	6	9	6	9
No. Stages	2	2	2	2
Gas Connection Pipe Size in. [mm]	0.5 [12.7]	0.75 [19]	0.5 [12.7]	0.75 [19]
Compressor				
No./Type	1/Scroll	1/Scroll	1/Scroll	1/Scroll
Outdoor Sound Rating (dB)⁵				
	88	88	88	88
Outdoor Coil—Fin Type				
Tube Type	Louvered	Louvered	Louvered	Louvered
MicroChannel Depth in. [mm]	MicroChannel	MicroChannel	MicroChannel	MicroChannel
Face Area sq. ft. [sq. m]	1 [25.4]	1 [25.4]	1 [25.4]	1 [25.4]
Rows / FPI [FPcm]	13.5 [1.25]	13.5 [1.25]	27 [2.51]	27 [2.51]
	1 / 23 [9]	1 / 23 [9]	1 / 23 [9]	1 / 23 [9]
Indoor Coil—Fin Type				
Tube Type	Louvered	Louvered	Louvered	Louvered
Tube Size in. [mm]	Rifled	Rifled	Rifled	Rifled
Face Area sq. ft. [sq. m]	0.375 [9.5]	0.375 [9.5]	0.375 [9.5]	0.375 [9.5]
Rows / FPI [FPcm]	13.5 [1.25]	13.5 [1.25]	13.5 [1.25]	13.5 [1.25]
	2 / 18 [7]	2 / 18 [7]	2 / 22 [9]	2 / 22 [9]
Refrigerant Control	Orifices	Orifices	Orifices	Orifices
Drain Connection No./Size in. [mm]	1/1 [25.4]	1/1 [25.4]	1/1 [25.4]	1/1 [25.4]
Outdoor Fan—Type				
No. Used/Diameter in. [mm]	Propeller	Propeller	Propeller	Propeller
Drive Type/No. Speeds	1/24 [609.6]	1/24 [609.6]	2/24 [609.6]	2/24 [609.6]
CFM [L/s]	Direct/1	Direct/1	Direct/1	Direct/1
No. Motors/HP	3749 [1769]	3749 [1769]	7000 [3303]	7000 [3303]
Motor RPM	1 at 1/2 HP	1 at 1/2 HP	2 at 1/3 HP	2 at 1/3 HP
	895	895	895	895
Indoor Fan—Type				
No. Used/Diameter in. [mm]	FC Centrifugal	FC Centrifugal	FC Centrifugal	FC Centrifugal
Drive Type/No. Speeds	1/15x15 [381x381]	1/15x15 [381x381]	1/15x15 [381x381]	1/15x15 [381x381]
No. Motors	Belt/Variable	Belt/Variable	Belt/Variable	Belt/Variable
Motor HP	1	1	1	1
Motor RPM	3	3	3	3
Motor Frame Size	1440	1440	1437	1437
	56	56	56	56
Filter—Type				
Furnished	Disposable	Disposable	Disposable	Disposable
(No.) Size Recommended in. [mm x mm x mm]	Yes	Yes	Yes	Yes
	(6)2x18x18 [51x457x457]	(6)2x18x18 [51x457x457]	(6)2x18x18 [51x457x457]	(6)2x18x18 [51x457x457]
Refrigerant Charge Oz. [g]				
	113.6 [3221]	113.6 [3221]	206.4 [5851]	206.4 [5851]
Weights				
Net Weight lbs. [kg]	890 [404]	926 [420]	1028 [466]	1064 [483]
Ship Weight lbs. [kg]	927 [420]	963 [437]	1065 [483]	1101 [499]

See Page 16 for Notes.

[] Designates Metric Conversions



NOM. SIZES 10 TON [35.2 kW] ASHRAE 90.1-2007 COMPLIANT MODELS

Model SKKL- Series	B120NM12E	B120NM18E	B120PL12E	B120PL18E
Cooling Performance¹				CONTINUED →
Gross Cooling Capacity Btu [kW]	104,000 [30.47]	104,000 [30.47]	104,000 [30.47]	104,000 [30.47]
EER/SEER ²	11.2/NA	11.2/NA	11.2/NA	11.2/NA
Rated CFM [L/s]	3000 [1416]	3000 [1416]	3000 [1416]	3000 [1416]
Net Cooling Capacity Btu [kW]	100,000 [29.3]	100,000 [29.3]	100,000 [29.3]	100,000 [29.3]
Net Sensible Capacity Btu [kW]	72,700 [21.3]	72,700 [21.3]	72,700 [21.3]	72,700 [21.3]
Net Latent Capacity Btu [kW]	27,300 [8]	27,300 [8]	27,300 [8]	27,300 [8]
IEER ³	11.9	11.9	11.9	11.9
Net System Power kW	8.86	8.86	8.86	8.86
Heating Performance (Gas)⁴				
Heating Input Btu [kW] (1st Stage / 2nd Stage)	60,000/120,000 [17.58/35.16]	90,000/180,000 [26.37/52.74]	60,000/120,000 [17.58/35.16]	90,000/180,000 [26.37/52.74]
Heating Output Btu [kW] (1st Stage / 2nd Stage)	48,600/97,200 [14.24/28.48]	72,900/145,800 [21.36/42.72]	48,600/97,200 [14.24/28.48]	72,900/145,800 [21.36/42.72]
Temperature Rise Range °F [°C] (1st Stage / 2nd Stage)	15-45 [8.3-25] / 15-45 [8.3-25]	25-55 [13.9-30.6] / 25-55 [13.9-30.6]	15-45 [8.3-25] / 15-45 [8.3-25]	25-55 [13.9-30.6] / 25-55 [13.9-30.6]
Steady State Efficiency (%)	81	81	81	81
No. Burners	6	9	6	9
No. Stages	2	2	2	2
Gas Connection Pipe Size in. [mm]	0.5 [12.7]	0.75 [19]	0.5 [12.7]	0.75 [19]
Compressor				
No./Type	1/Scroll	1/Scroll	1/Scroll	1/Scroll
Outdoor Sound Rating (dB)⁵				
	88	88	88	88
Outdoor Coil—Fin Type				
Tube Type	Louvered	Louvered	Louvered	Louvered
MicroChannel Depth in. [mm]	MicroChannel	MicroChannel	MicroChannel	MicroChannel
Face Area sq. ft. [sq. m]	1 [25.4]	1 [25.4]	1 [25.4]	1 [25.4]
Rows / FPI [FPCm]	27 [2.51]	27 [2.51]	27 [2.51]	27 [2.51]
	1 / 23 [9]	1 / 23 [9]	1 / 23 [9]	1 / 23 [9]
Indoor Coil—Fin Type				
Tube Type	Louvered	Louvered	Louvered	Louvered
Tube Size in. [mm]	Rifled	Rifled	Rifled	Rifled
Face Area sq. ft. [sq. m]	0.375 [9.5]	0.375 [9.5]	0.375 [9.5]	0.375 [9.5]
Rows / FPI [FPCm]	13.5 [1.25]	13.5 [1.25]	13.5 [1.25]	13.5 [1.25]
Refrigerant Control	2 / 22 [9]	2 / 22 [9]	2 / 22 [9]	2 / 22 [9]
Drain Connection No./Size in. [mm]	Orifices	Orifices	Orifices	Orifices
	1/1 [25.4]	1/1 [25.4]	1/1 [25.4]	1/1 [25.4]
Outdoor Fan—Type				
No. Used/Diameter in. [mm]	Propeller	Propeller	Propeller	Propeller
Drive Type/No. Speeds	2/24 [609.6]	2/24 [609.6]	2/24 [609.6]	2/24 [609.6]
CFM [L/s]	Direct/1	Direct/1	Direct/1	Direct/1
No. Motors/HP	7000 [3303]	7000 [3303]	7000 [3303]	7000 [3303]
Motor RPM	2 at 1/3 HP	2 at 1/3 HP	2 at 1/3 HP	2 at 1/3 HP
	895	895	895	895
Indoor Fan—Type				
No. Used/Diameter in. [mm]	FC Centrifugal	FC Centrifugal	FC Centrifugal	FC Centrifugal
Drive Type/No. Speeds	1/15x15 [381x381]	1/15x15 [381x381]	1/15x15 [381x381]	1/15x15 [381x381]
No. Motors	Belt/Variable	Belt/Variable	Belt/Variable	Belt/Variable
Motor HP	1	1	1	1
Motor RPM	3	3	3	3
Motor Frame Size	1437	1437	1437	1437
	56	56	56	56
Filter—Type				
Furnished	Disposable	Disposable	Disposable	Disposable
(No.) Size Recommended in. [mm x mm x mm]	Yes	Yes	Yes	Yes
	(6)2x18x18 [51x457x457]	(6)2x18x18 [51x457x457]	(6)2x18x18 [51x457x457]	(6)2x18x18 [51x457x457]
Refrigerant Charge Oz. [g]				
	206.4 [5851]	206.4 [5851]	206.4 [5851]	206.4 [5851]
Weights				
Net Weight lbs. [kg]	1028 [466]	1064 [483]	1028 [466]	1064 [483]
Ship Weight lbs. [kg]	1065 [483]	1101 [499]	1065 [483]	1101 [499]

See Page 16 for Notes.

[] Designates Metric Conversions



NOM. SIZES 12.5 TON [44.0 kW] ASHRAE 90.1-2007 COMPLIANT MODELS

Model SKKL- Series	B151NL12E	B151NL21E	B151NM12E	B151NM21E
Cooling Performance¹				
Gross Cooling Capacity Btu [kW]	130,000 [38.09]	130,000 [38.09]	130,000 [38.09]	130,000 [38.09]
EER/SEER ²	11.4/NA	11.4/NA	11.4/NA	11.4/NA
Rated CFM [L/s]	3500 [1652]	3500 [1652]	3500 [1652]	3500 [1652]
Net Cooling Capacity Btu [kW]	126,000 [36.92]	126,000 [36.92]	126,000 [36.92]	126,000 [36.92]
Net Sensible Capacity Btu [kW]	89,100 [26.11]	89,100 [26.11]	89,100 [26.11]	89,100 [26.11]
Net Latent Capacity Btu [kW]	36,900 [10.81]	36,900 [10.81]	36,900 [10.81]	36,900 [10.81]
IEER ³	12.5	12.5	12.5	12.5
Net System Power kW	11.11	11.11	11.11	11.11
Heating Performance (Gas)⁴				
Heating Input Btu [kW] (1st Stage / 2nd Stage)	60,000/120,000 [17.58/35.16]	105,000/210,000 [30.76/61.53]	60,000/120,000 [17.58/35.16]	105,000/210,000 [30.76/61.53]
Heating Output Btu [kW] (1st Stage / 2nd Stage)	48,600/97,200 [14.24/28.48]	85,000/170,000 [24.9/49.81]	48,600/97,200 [14.24/28.48]	85,000/170,000 [24.9/49.81]
Temperature Rise Range °F [°C] (1st Stage / 2nd Stage)	15-45 [8.3-25] / 15-45 [8.3-25]	25-55 [13.9-30.6] / 25-55 [13.9-30.6]	15-45 [8.3-25] / 15-45 [8.3-25]	25-55 [13.9-30.6] / 25-55 [13.9-30.6]
Steady State Efficiency (%)	81	81	81	81
No. Burners	6	9	6	9
No. Stages	2	2	2	2
Gas Connection Pipe Size in. [mm]	0.5 [12.7]	0.75 [19]	0.5 [12.7]	0.75 [19]
Compressor				
No./Type	2/Scroll	2/Scroll	2/Scroll	2/Scroll
Outdoor Sound Rating (dB)⁵				
	88	88	88	88
Outdoor Coil—Fin Type				
Tube Type	Louvered	Louvered	Louvered	Louvered
MicroChannel Depth in. [mm]	MicroChannel	MicroChannel	MicroChannel	MicroChannel
Face Area sq. ft. [sq. m]	1 [25.4]	1 [25.4]	1 [25.4]	1 [25.4]
Rows / FPI [FPcm]	27 [2.51]	27 [2.51]	27 [2.51]	27 [2.51]
	2 / 23 [9]	2 / 23 [9]	2 / 23 [9]	2 / 23 [9]
Indoor Coil—Fin Type				
Tube Type	Louvered	Louvered	Louvered	Louvered
Tube Size in. [mm]	Rifled	Rifled	Rifled	Rifled
Face Area sq. ft. [sq. m]	0.375 [9.5]	0.375 [9.5]	0.375 [9.5]	0.375 [9.5]
Rows / FPI [FPcm]	13.5 [1.25]	13.5 [1.25]	13.5 [1.25]	13.5 [1.25]
Refrigerant Control	4 / 15 [6]	4 / 15 [6]	4 / 15 [6]	4 / 15 [6]
Drain Connection No./Size in. [mm]	TX Valves	TX Valves	TX Valves	TX Valves
	1/1 [25.4]	1/1 [25.4]	1/1 [25.4]	1/1 [25.4]
Outdoor Fan—Type				
No. Used/Diameter in. [mm]	Propeller	Propeller	Propeller	Propeller
Drive Type/No. Speeds	2/24 [609.6]	2/24 [609.6]	2/24 [609.6]	2/24 [609.6]
CFM [L/s]	Direct/1	Direct/1	Direct/1	Direct/1
No. Motors/HP	6667 [3146]	6667 [3146]	6667 [3146]	6667 [3146]
Motor RPM	2 at 1/2 HP	2 at 1/2 HP	2 at 1/2 HP	2 at 1/2 HP
	895	895	895	895
Indoor Fan—Type				
No. Used/Diameter in. [mm]	FC Centrifugal	FC Centrifugal	FC Centrifugal	FC Centrifugal
Drive Type/No. Speeds	1/15x15 [381x381]	1/15x15 [381x381]	1/15x15 [381x381]	1/15x15 [381x381]
No. Motors	Belt/Variable	Belt/Variable	Belt/Variable	Belt/Variable
Motor HP	1	1	1	1
Motor RPM	5	5	5	5
Motor Frame Size	1440	1440	1440	1440
	184	184	184	184
Filter—Type				
Furnished	Disposable	Disposable	Disposable	Disposable
(No.) Size Recommended in. [mm x mm x mm]	Yes	Yes	Yes	Yes
	(6)2x18x18 [51x457x457]	(6)2x18x18 [51x457x457]	(6)2x18x18 [51x457x457]	(6)2x18x18 [51x457x457]
Refrigerant Charge Oz. (Sys. 1/Sys. 2) [g]				
	147.2/152 [4173/4309]	147.2/152 [4173/4309]	147.2/152 [4173/4309]	147.2/152 [4173/4309]
Weights				
Net Weight lbs. [kg]	1238 [562]	1274 [578]	1238 [562]	1274 [578]
Ship Weight lbs. [kg]	1275 [578]	1311 [595]	1275 [578]	1311 [595]

See Page 16 for Notes.

[] Designates Metric Conversions

**NOM. SIZES 12.5 TON [44.0 kW] ASHRAE 90.1-2007 COMPLIANT MODELS**

Model SKKL- Series	B151PL12E	B151PL21E
Cooling Performance¹		
Gross Cooling Capacity Btu [kW]	130,000 [38.09]	130,000 [38.09]
EER/SEER ²	11.4/NA	11.4/NA
Rated CFM [L/s]	3500 [1652]	3500 [1652]
Net Cooling Capacity Btu [kW]	126,000 [36.92]	126,000 [36.92]
Net Sensible Capacity Btu [kW]	89,100 [26.11]	89,100 [26.11]
Net Latent Capacity Btu [kW]	36,900 [10.81]	36,900 [10.81]
IEER ³	12.5	12.5
Net System Power kW	11.11	11.11
Heating Performance (Gas)⁴		
Heating Input Btu [kW] (1st Stage / 2nd Stage)	60,000/120,000 [17.58/35.16]	105,000/210,000 [30.76/61.53]
Heating Output Btu [kW] (1st Stage / 2nd Stage)	48,600/97,200 [14.24/28.48]	85,000/170,000 [24.9/49.81]
Temperature Rise Range °F [°C] (1st Stage / 2nd Stage)	15-45 [8.3-25] / 15-45 [8.3-25]	25-55 [13.9-30.6] / 25-55 [13.9-30.6]
Steady State Efficiency (%)	81	81
No. Burners	6	9
No. Stages	2	2
Gas Connection Pipe Size in. [mm]	0.5 [12.7]	0.75 [19]
Compressor		
No./Type	2/Scroll	2/Scroll
Outdoor Sound Rating (dB)⁵		
	88	88
Outdoor Coil—Fin Type		
	Louvered	Louvered
Tube Type	MicroChannel	MicroChannel
MicroChannel Depth in. [mm]	1 [25.4]	1 [25.4]
Face Area sq. ft. [sq. m]	27 [2.51]	27 [2.51]
Rows / FPI [FPcm]	2 / 23 [9]	2 / 23 [9]
Indoor Coil—Fin Type		
Tube Type	Rifled	Rifled
Tube Size in. [mm]	0.375 [9.5]	0.375 [9.5]
Face Area sq. ft. [sq. m]	13.5 [1.25]	13.5 [1.25]
Rows / FPI [FPcm]	4 / 15 [6]	4 / 15 [6]
Refrigerant Control	TX Valves	TX Valves
Drain Connection No./Size in. [mm]	1/1 [25.4]	1/1 [25.4]
Outdoor Fan—Type		
	Propeller	Propeller
No. Used/Diameter in. [mm]	2/24 [609.6]	2/24 [609.6]
Drive Type/No. Speeds	Direct/1	Direct/1
CFM [L/s]	6667 [3146]	6667 [3146]
No. Motors/HP	2 at 1/2 HP	2 at 1/2 HP
Motor RPM	895	895
Indoor Fan—Type		
	FC Centrifugal	FC Centrifugal
No. Used/Diameter in. [mm]	1/15x15 [381x381]	1/15x15 [381x381]
Drive Type/No. Speeds	Belt/Variable	Belt/Variable
No. Motors	1	1
Motor HP	5	5
Motor RPM	1440	1440
Motor Frame Size	184	184
Filter—Type		
	Disposable	Disposable
Furnished	Yes	Yes
(No.) Size Recommended in. [mm x mm x mm]	(6)2x18x18 [51x457x457]	(6)2x18x18 [51x457x457]
Refrigerant Charge Oz. (Sys. 1/Sys. 2) [g]		
	147.2/152 [4173/4309]	147.2/152 [4173/4309]
Weights		
Net Weight lbs. [kg]	1238 [562]	1274 [578]
Ship Weight lbs. [kg]	1275 [578]	1311 [595]

See Page 16 for Notes.

[] Designates Metric Conversions



NOTES:

1. Cooling Performance is rated at 95° F ambient, 80° F entering dry bulb, 67° F entering wet bulb. Gross capacity does not include the effect of fan motor heat. AHRI capacity is net and includes the effect of fan motor heat. Units are suitable for operation to $\pm 20\%$ of nominal cfm. Units are certified in accordance with the Unitary Air Conditioner Equipment certification program, which is based on AHRI Standard 340/360.
2. EER and/or SEER are rated at AHRI conditions and in accordance with DOE test procedures.
3. IEER is rated in accordance with AHRI Standard 340/360.
4. Heating Performance limit settings and rating data were established and approved under laboratory test conditions using American National Standard Institute standards. Ratings shown are for elevations up to 2000 feet. For elevations above 2000 feet, ratings should be reduced at the rate of 4% for each 1000 feet above sea level.
5. Outdoor Sound Rating shown is tested in accordance with AHRI Standard 270.



GROSS SYSTEMS PERFORMANCE DATA—B090

		ENTERING INDOOR AIR @ 80°F [26.7°C] ①									
		71°F [21.7°C]			67°F [19.4°C]			63°F [17.2°C]			
wbE		2940 [1388]	2400 [1133]	1960 [925]	2940 [1388]	2400 [1133]	1960 [925]	2940 [1388]	2400 [1133]	1960 [925]	
CFM [L/s]											
DR ①		.03	.07	.10	.03	.07	.10	.03	.07	.10	
OUTDOOR DRY BULB TEMPERATURE °F [°C]	75 [23.9]	Total BTUH [kW] Sens BTUH [kW] Power	89.7 [26.3] 60.9 [17.8] 4.7	86.2 [25.3] 51.6 [15.1] 4.6	83.3 [24.4] 44.5 [15.1] 4.5	86.1 [25.2] 71.7 [21.0] 4.6	82.8 [24.3] 61.6 [18.0] 4.5	80.0 [23.4] 53.8 [18.0] 4.4	82.3 [24.1] 79.9 [23.4] 4.5	79.1 [23.2] 69.1 [20.2] 4.4	76.4 [22.4] 60.7 [20.2] 4.3
	80 [26.7]	Total BTUH [kW] Sens BTUH [kW] Power	88.0 [25.8] 60.0 [17.6] 4.9	84.5 [24.8] 50.8 [14.9] 4.8	81.7 [23.9] 43.9 [14.9] 4.7	84.4 [24.7] 70.8 [20.7] 4.8	81.1 [23.8] 60.8 [17.8] 4.7	78.4 [23.0] 53.1 [17.8] 4.6	80.6 [23.6] 79.0 [23.1] 4.7	77.4 [22.7] 68.3 [20.0] 4.6	74.8 [21.9] 60.1 [20.0] 4.5
	85 [29.4]	Total BTUH [kW] Sens BTUH [kW] Power	86.0 [25.2] 58.9 [17.3] 5.2	82.6 [24.2] 49.9 [14.6] 5.1	79.8 [23.4] 43.1 [14.6] 5.0	82.4 [24.1] 69.7 [20.4] 5.0	79.2 [23.2] 59.9 [17.6] 5.0	76.5 [22.4] 52.3 [17.6] 4.9	78.6 [23.0] 77.9 [22.8] 4.9	75.5 [22.1] 67.4 [19.7] 4.8	72.9 [21.4] 59.3 [19.7] 4.8
	90 [32.2]	Total BTUH [kW] Sens BTUH [kW] Power	83.6 [24.5] 57.5 [16.8] 5.4	80.3 [23.5] 48.7 [14.3] 5.3	77.6 [22.7] 42.1 [14.3] 5.2	80.0 [23.4] 68.3 [20.0] 5.3	76.9 [22.5] 58.7 [17.2] 5.2	74.3 [21.8] 51.3 [17.2] 5.1	76.2 [22.3] 76.2 [22.3] 5.2	73.2 [21.4] 66.3 [19.4] 5.1	70.8 [20.7] 58.4 [19.4] 5.0
	95 [35]	Total BTUH [kW] Sens BTUH [kW] Power	80.9 [23.7] 55.8 [16.3] 5.7	77.7 [22.8] 47.3 [13.9] 5.6	75.2 [22.0] 41.0 [13.9] 5.5	77.4 [22.7] 66.7 [19.5] 5.6	74.3 [21.8] 57.3 [16.8] 5.5	71.8 [21.0] 50.1 [16.8] 5.4	73.5 [21.5] 73.5 [21.5] 5.5	70.6 [20.7] 64.9 [19.0] 5.4	68.3 [20.0] 57.2 [19.0] 5.3
	100 [37.8]	Total BTUH [kW] Sens BTUH [kW] Power	77.9 [22.8] 54.0 [15.8] 6.0	74.9 [21.9] 45.9 [13.4] 5.9	72.4 [21.2] 39.7 [13.4] 5.8	74.4 [21.8] 64.9 [19.0] 5.9	71.4 [20.9] 55.7 [16.3] 5.8	69.1 [20.2] 48.8 [16.3] 5.7	70.5 [20.7] 70.5 [20.7] 5.8	67.8 [19.9] 63.4 [18.6] 5.7	65.5 [19.2] 55.9 [18.6] 5.6
	105 [40.6]	Total BTUH [kW] Sens BTUH [kW] Power	74.6 [21.9] 51.9 [15.2] 6.3	71.7 [21.0] 44.1 [12.9] 6.2	69.3 [20.3] 38.1 [12.9] 6.1	71.1 [20.8] 62.8 [18.4] 6.2	68.3 [20.0] 54.0 [15.8] 6.1	66.0 [19.3] 47.3 [15.8] 6.0	67.2 [19.7] 67.2 [19.7] 6.1	64.6 [18.9] 61.6 [18.0] 6.0	62.4 [18.3] 54.3 [18.0] 5.9
	110 [43.3]	Total BTUH [kW] Sens BTUH [kW] Power	71.0 [20.8] 49.6 [14.5] 6.7	68.2 [20.0] 42.1 [12.3] 6.6	65.9 [19.3] 36.4 [12.3] 6.5	67.4 [19.7] 60.4 [17.7] 6.6	64.8 [19.0] 52.1 [15.3] 6.4	62.6 [18.3] 45.6 [15.3] 6.3	63.6 [18.6] 63.6 [18.6] 6.5	61.1 [17.9] 59.6 [17.5] 6.3	59.0 [17.3] 52.6 [17.3] 6.2
	115 [46.1]	Total BTUH [kW] Sens BTUH [kW] Power	67.0 [19.6] 47.0 [13.8] 7.0	64.4 [18.9] 39.9 [11.7] 6.9	62.2 [18.2] 34.5 [11.7] 6.8	63.4 [18.6] 57.8 [16.9] 6.9	61.0 [17.9] 49.9 [14.6] 6.8	58.9 [17.3] 43.7 [14.6] 6.7	59.6 [17.5] 59.6 [17.5] 6.8	57.3 [16.8] 57.3 [16.8] 6.7	55.3 [16.2] 50.8 [16.2] 6.6
	120 [48.9]	Total BTUH [kW] Sens BTUH [kW] Power	62.7 [18.4] 44.2 [13.0] 7.4	60.3 [17.7] 37.6 [11.0] 7.3	58.2 [17.1] 32.5 [11.0] 7.2	59.2 [17.3] 55.0 [16.1] 7.3	56.8 [16.6] 47.4 [13.9] 7.2	54.9 [16.1] 41.6 [13.9] 7.1	55.3 [16.2] 55.3 [16.2] 7.2	53.1 [15.6] 53.1 [15.6] 7.1	51.4 [15.1] 48.7 [15.1] 7.0

DR —Depression ratio
dbE—Entering air dry bulb
wbE—Entering air wet bulb

Total —Total capacity x 1000 BTUH
Sens —Sensible capacity x 1000 BTUH
Power—kW input

NOTES: ① When the entering air dry bulb is other than 80°F [27°C], adjust the sensible capacity from the table by adding [1.10 x CFM x (1 – DR) x (dbE – 80)].

[] Designates Metric Conversions



GROSS SYSTEMS PERFORMANCE DATA—B120

		ENTERING INDOOR AIR @ 80°F [26.7°C] ①									
wbE		71°F [21.7°C]			67°F [19.4°C]			63°F [17.2°C]			
CFM [L/s]		4000 [1188]	3000 [1416]	2600 [1227]	4000 [1188]	3000 [1416]	2600 [1227]	4000 [1188]	3000 [1416]	2600 [1227]	
DR ①		.0	.05	.08	.0	.05	.08	.0	.05	.08	
OUTDOOR DRY BULB TEMPERATURE °F [°C]	75 [23.9]	Total BTUH [kW] Sens BTUH [kW] Power	129.9 [38.1] 89.0 [26.1] 6.8	122.5 [35.9] 69.6 [20.4] 6.6	119.5 [35.0] 62.5 [20.4] 6.5	123.5 [36.2] 103.4 [30.3] 6.6	116.5 [34.1] 82.5 [24.2] 6.4	113.6 [33.3] 74.6 [24.2] 6.3	118.2 [34.6] 116.6 [34.2] 6.4	111.4 [32.6] 94.1 [27.6] 6.3	108.7 [31.8] 85.7 [27.6] 6.2
	80 [26.7]	Total BTUH [kW] Sens BTUH [kW] Power	127.0 [37.2] 87.2 [25.5] 7.1	119.8 [35.1] 68.3 [20.0] 6.9	116.9 [34.3] 61.3 [20.0] 6.8	120.7 [35.4] 101.8 [29.8] 6.9	113.8 [33.3] 81.2 [23.8] 6.7	111.0 [32.5] 73.5 [23.8] 6.6	115.3 [33.8] 115.0 [33.7] 6.7	108.7 [31.8] 92.9 [27.2] 6.6	106.1 [31.1] 84.7 [27.2] 6.5
	85 [29.4]	Total BTUH [kW] Sens BTUH [kW] Power	123.9 [36.3] 85.5 [25.1] 7.4	116.8 [34.2] 66.9 [19.6] 7.2	114.0 [33.4] 60.1 [19.6] 7.1	117.5 [34.4] 100.0 [29.3] 7.2	110.8 [32.5] 79.8 [23.4] 7.0	108.1 [31.7] 72.3 [23.4] 6.9	112.2 [32.9] 112.2 [32.9] 7.1	105.8 [31.0] 91.6 [26.8] 6.9	103.2 [30.2] 83.5 [26.8] 6.8
	90 [32.2]	Total BTUH [kW] Sens BTUH [kW] Power	120.4 [35.3] 83.5 [24.5] 7.7	113.5 [33.3] 65.4 [19.2] 7.5	110.8 [32.5] 58.8 [19.2] 7.4	114.1 [33.4] 98.1 [28.7] 7.6	107.5 [31.5] 78.3 [22.9] 7.3	104.9 [30.7] 71.0 [22.9] 7.3	108.7 [31.8] 108.7 [31.8] 7.4	102.5 [30.0] 90.0 [26.4] 7.2	100.0 [29.3] 82.1 [26.4] 7.1
	95 [35]	Total BTUH [kW] Sens BTUH [kW] Power	116.6 [34.2] 81.4 [23.8] 8.1	110.0 [32.2] 63.8 [18.7] 7.8	107.3 [31.4] 57.3 [18.7] 7.8	110.3 [32.3] 95.9 [28.1] 7.9	104.0 [30.5] 76.7 [22.5] 7.7	101.5 [29.7] 69.6 [22.5] 7.6	104.9 [30.7] 104.9 [30.7] 7.8	98.9 [29.0] 88.4 [25.9] 7.5	96.5 [28.3] 80.6 [25.9] 7.4
	100 [37.8]	Total BTUH [kW] Sens BTUH [kW] Power	112.6 [33.0] 79.0 [23.1] 8.4	106.1 [31.1] 61.9 [18.1] 8.2	103.6 [30.4] 55.7 [18.1] 8.1	106.2 [31.1] 93.6 [27.4] 8.3	100.2 [29.4] 75.0 [22.0] 8.0	97.7 [28.6] 68.0 [22.0] 8.0	100.9 [29.6] 100.9 [29.6] 8.1	95.1 [27.9] 86.6 [25.4] 7.9	92.8 [27.2] 79.1 [25.4] 7.8
	105 [40.6]	Total BTUH [kW] Sens BTUH [kW] Power	108.2 [31.7] 76.6 [22.4] 8.8	102.0 [29.9] 60.1 [17.6] 8.6	99.5 [29.2] 54.0 [17.6] 8.5	101.9 [29.9] 91.2 [26.7] 8.7	96.0 [28.1] 73.0 [21.4] 8.4	93.7 [27.5] 66.3 [21.4] 8.3	96.5 [28.3] 96.5 [28.3] 8.5	91.0 [26.7] 84.8 [24.8] 8.3	88.8 [26.0] 77.5 [24.8] 8.2
	110 [43.3]	Total BTUH [kW] Sens BTUH [kW] Power	103.5 [30.3] 74.0 [21.7] 9.2	97.6 [28.6] 58.1 [17.0] 9.0	95.2 [27.9] 52.2 [17.0] 8.9	97.2 [28.5] 88.5 [25.9] 9.1	91.6 [26.8] 71.0 [20.8] 8.8	89.4 [26.2] 64.5 [20.8] 8.7	91.8 [26.9] 91.8 [26.9] 8.9	86.6 [25.4] 82.8 [24.3] 8.7	84.5 [24.8] 75.7 [24.3] 8.6
	115 [46.1]	Total BTUH [kW] Sens BTUH [kW] Power	98.5 [28.9] 71.1 [20.8] 9.7	92.9 [27.2] 55.9 [16.4] 9.4	90.7 [26.6] 50.4 [16.4] 9.3	92.2 [27.0] 85.7 [25.1] 9.5	86.9 [25.5] 68.9 [20.2] 9.2	84.8 [24.8] 62.6 [20.2] 9.1	86.8 [25.4] 86.8 [25.4] 9.4	81.9 [24.0] 80.6 [23.6] 9.1	79.9 [23.4] 73.7 [23.4] 9.0
	120 [48.9]	Total BTUH [kW] Sens BTUH [kW] Power	93.3 [27.3] 68.2 [20.0] 10.1	87.9 [25.8] 53.6 [15.7] 9.8	85.8 [25.1] 48.3 [15.7] 9.7	86.9 [25.5] 82.7 [24.2] 10.0	81.9 [24.0] 66.6 [19.5] 9.7	80.0 [23.4] 60.7 [19.5] 9.6	81.6 [23.9] 81.6 [23.9] 9.8	76.9 [22.5] 76.9 [22.5] 9.5	75.0 [22.0] 71.6 [22.0] 9.4

DR —Depression ratio
dbE —Entering air dry bulb
wbE—Entering air wet bulb

Total —Total capacity x 1000 BTUH
Sens —Sensible capacity x 1000 BTUH
Power—kW input

NOTES: ① When the entering air dry bulb is other than 80°F [27°C], adjust the sensible capacity from the table by adding $[1.10 \times \text{CFM} \times (1 - \text{DR}) \times (\text{dbE} - 80)]$.

[] Designates Metric Conversions



GROSS SYSTEMS PERFORMANCE DATA—B151

		ENTERING INDOOR AIR @ 80°F [26.7°C] dbE ①									
		71°F [21.7°C]			67°F [19.4°C]			63°F [17.2°C]			
wbE		4980 [2351]	3500 [1652]	3320 [1567]	4980 [2351]	3500 [1652]	3320 [1567]	4980 [2351]	3500 [1652]	3320 [1567]	
CFM [L/s]		4980 [2351]	3500 [1652]	3320 [1567]	4980 [2351]	3500 [1652]	3320 [1567]	4980 [2351]	3500 [1652]	3320 [1567]	
DR ①		0.01	0.04	0.06	0.01	0.04	0.06	0.01	0.04	0.06	
OUTDOOR DRY BULB TEMPERATURE	75 [23.9]	Total BTUH [kW]	166.9 [48.9]	154.9 [45.4]	153.5 [45.0]	157.5 [46.1]	146.3 [42.9]	144.9 [42.5]	149.4 [43.8]	138.7 [40.6]	137.4 [40.3]
		Sens BTUH [kW]	116.6 [34.2]	85.4 [25.0]	82.0 [25.0]	134.3 [39.3]	101.0 [29.6]	97.2 [29.6]	149.4 [43.8]	115.7 [33.9]	111.7 [33.9]
		Power	8.5	8.2	8.2	8.3	8.0	8.0	8.1	7.8	7.8
	80 [26.7]	Total BTUH [kW]	162.8 [47.7]	151.2 [44.3]	149.8 [43.9]	153.5 [45.0]	142.5 [41.8]	141.2 [41.4]	145.3 [42.6]	134.9 [39.5]	133.7 [39.2]
		Sens BTUH [kW]	114.1 [33.4]	83.7 [24.5]	80.3 [24.5]	131.8 [38.6]	99.1 [29.0]	95.5 [29.0]	145.3 [42.6]	113.9 [33.4]	110.0 [33.4]
		Power	9.0	8.7	8.6	8.8	8.5	8.4	8.6	8.3	8.2
	85 [29.4]	Total BTUH [kW]	158.6 [46.5]	147.2 [43.1]	145.9 [42.7]	149.2 [43.7]	138.6 [40.6]	137.3 [40.2]	141.1 [41.3]	131.0 [38.4]	129.8 [38.0]
		Sens BTUH [kW]	111.5 [32.7]	81.7 [23.9]	78.5 [23.9]	129.2 [37.9]	97.3 [28.5]	93.7 [28.5]	141.1 [41.3]	112.0 [32.8]	108.1 [32.8]
		Power	9.5	9.1	9.1	9.2	8.9	8.9	9.0	8.7	8.7
	90 [32.2]	Total BTUH [kW]	154.1 [45.2]	143.1 [41.9]	141.8 [41.5]	144.8 [42.4]	134.4 [39.4]	133.2 [39.0]	136.6 [40.0]	126.9 [37.2]	125.7 [36.8]
Sens BTUH [kW]		108.7 [31.8]	79.8 [23.4]	76.6 [23.4]	126.6 [37.1]	95.3 [27.9]	91.8 [27.9]	136.6 [40.0]	110.1 [32.3]	106.3 [32.3]	
Power		9.9	9.6	9.5	9.7	9.4	9.4	9.5	9.2	9.2	
95 [35]	Total BTUH [kW]	149.5 [43.8]	138.8 [40.7]	137.5 [40.3]	140.1 [41.0]	130.1 [38.1]	128.9 [37.8]	132.0 [38.7]	122.6 [35.9]	121.4 [35.6]	
	Sens BTUH [kW]	105.8 [31.0]	77.7 [22.8]	74.6 [22.8]	123.6 [36.2]	93.2 [27.3]	89.8 [27.3]	132.0 [38.7]	108.0 [31.6]	104.2 [31.6]	
	Power	10.5	10.1	10.0	10.3	9.9	9.9	10.1	9.7	9.7	
100 [37.8]	Total BTUH [kW]	144.6 [42.4]	134.3 [39.3]	133.1 [39.0]	135.3 [39.6]	125.6 [36.8]	124.5 [36.5]	127.1 [37.2]	118.1 [34.6]	117.0 [34.3]	
	Sens BTUH [kW]	102.9 [30.1]	75.6 [22.2]	72.6 [22.2]	120.6 [35.3]	91.0 [26.7]	87.7 [26.7]	127.1 [37.2]	105.9 [31.0]	102.3 [31.0]	
	Power	11.0	10.6	10.6	10.8	10.4	10.4	10.6	10.2	10.2	
105 [40.6]	Total BTUH [kW]	139.6 [40.9]	129.6 [38.0]	128.4 [37.6]	130.3 [38.2]	121.0 [35.5]	119.8 [35.1]	122.1 [35.8]	113.4 [33.2]	112.3 [32.9]	
	Sens BTUH [kW]	99.7 [29.2]	73.3 [21.5]	70.4 [21.5]	117.6 [34.5]	88.9 [26.0]	85.6 [26.0]	122.1 [35.8]	103.6 [30.4]	100.0 [30.4]	
	Power	11.6	11.2	11.1	11.4	11.0	10.9	11.2	10.8	10.7	
110 [43.3]	Total BTUH [kW]	134.4 [39.4]	124.8 [36.6]	123.6 [36.2]	125.1 [36.7]	116.1 [34.0]	115.0 [33.7]	116.9 [34.3]	108.5 [31.8]	107.5 [31.5]	
	Sens BTUH [kW]	96.5 [28.3]	71.0 [20.8]	68.1 [20.8]	114.3 [33.5]	86.5 [25.3]	83.4 [25.3]	116.9 [34.3]	101.2 [29.7]	97.8 [29.7]	
	Power	12.2	11.8	11.7	12.0	11.6	11.5	11.8	11.4	11.3	
115 [46.1]	Total BTUH [kW]	129.0 [37.8]	119.8 [35.1]	118.6 [34.7]	119.6 [35.0]	111.1 [32.6]	110.1 [32.3]	111.5 [32.7]	103.5 [30.3]	102.5 [30.0]	
	Sens BTUH [kW]	93.2 [27.3]	68.6 [20.1]	65.8 [20.1]	110.9 [32.5]	84.1 [24.6]	81.1 [24.6]	111.5 [32.7]	98.8 [28.9]	95.5 [28.9]	
	Power	12.8	12.4	12.3	12.6	12.2	12.1	12.4	12.0	11.9	
120 [48.9]	Total BTUH [kW]	123.4 [36.2]	114.6 [33.6]	113.5 [33.3]	114.0 [33.4]	105.9 [31.0]	104.9 [30.7]	105.9 [31.0]	98.3 [28.8]	97.4 [28.5]	
	Sens BTUH [kW]	89.7 [26.3]	66.1 [19.4]	63.4 [19.4]	107.4 [31.5]	81.6 [23.9]	78.7 [23.9]	105.9 [31.0]	96.3 [28.2]	93.1 [28.2]	
	Power	13.5	13.0	12.9	13.3	12.8	12.7	13.1	12.6	12.5	

DR —Depression ratio
 dbE—Entering air dry bulb
 wbE—Entering air wet bulb

Total —Total capacity x 1000 BTUH
 Sens —Sensible capacity x 1000 BTUH
 Power—kW input

NOTES: ① When the entering air dry bulb is other than 80°F [27°C], adjust the sensible capacity from the table by adding $[1.10 \times \text{CFM} \times (1 - \text{DR}) \times (\text{dbE} - 80)]$.

[] Designates Metric Conversions



AIRFLOW PERFORMANCE—7.5 TON [26.4 kW]—50 HZ

Air Flow CFM [L/s]	Capacity 7.5 Ton [26.4 kW]																															
	External Static Pressure—Inches of Water [kPa]																															
	0.1 [.02]		0.2 [.05]		0.3 [.07]		0.4 [.10]		0.5 [.12]		0.6 [.15]		0.7 [.17]		0.8 [.20]		0.9 [.22]		1.0 [.25]		1.1 [.27]		1.2 [.30]		1.3 [.32]		1.4 [.35]		1.5 [.37]			
	RPM	W	RPM	W	RPM	W	RPM	W	RPM	W	RPM	W	RPM	W	RPM	W	RPM	W	RPM	W	RPM	W	RPM	W	RPM	W	RPM	W	RPM	W	RPM	W
2000 [944]	—	—	—	—	—	—	589	536	615	587	648	610	676	649	706	711	735	773	764	835	794	898	818	960	852	1020	900	1282	933	1581		
2200 [1038]	—	—	—	—	—	—	605	633	652	694	725	694	769	723	831	752	893	782	956	811	1018	837	1080	871	1150	914	1410	946	1603	—		
2400 [1133]	—	—	—	—	594	744	623	780	652	816	682	854	711	890	740	952	770	1014	799	1076	828	1138	857	1200	887	1261	929	1538	958	1623		
2600 [1227]	—	—	—	—	602	816	633	858	664	901	699	948	729	1010	758	1072	787	1134	816	1196	846	1258	875	1320	914	1581	943	1666	—	—		
2800 [1321]	—	—	593	884	623	929	653	974	684	1020	717	1069	748	1131	775	1192	804	1254	834	1316	863	1378	892	1440	928	1709	958	1794	—	—		
3000 [1416]	—	—	608	972	638	1020	669	1069	705	1127	734	1189	763	1251	792	1313	822	1375	851	1437	880	1498	913	1752	943	1837	—	—	—	—		

NOTE: L-Drive left of bold line, M-Drive right of bold line.

Drive Package	L	M
Motor H.P. [W]	3.0 [2237.1]	3.0 [2237.1]
Blower Sheave	BK90	BK65
Motor Sheave	1VP-44	1VP-44
Turns Open	1 2 3 4	1 2 3 4
RPM	721 695 669 642 616 589	917 876 834 792 750

NOTES: 1. Factory sheave settings are shown in bold print.
2. Do not set motor sheave below one turn open.

AIRFLOW CORRECTION FACTORS 7.5 TON [26.4 kW]

ACTUAL—CFM [L/s]	2000 [944]	2200 [1038]	2400 [1133]	2600 [1227]	2800 [1321]	3000 [1416]
TOTAL MBH	.96	.97	.98	1.00	1.01	1.02
SENSIBLE MBH	.89	.92	.96	.99	1.03	1.06
POWER kW	.98	.99	1.00	1.00	1.01	1.02

NOTES: 1. Multiply correction factor times gross performance data.
2. Resulting sensible capacity cannot exceed total capacity.

[] Designates Metric Conversions

COMPONENT AIR RESISTANCE, IWC 7.5 TON [26.4 kW]

Component	Standard Indoor Airflow—CFM [L/s]					
	2000 [944]	2200 [1038]	2400 [1133]	2600 [1227]	2800 [1321]	3000 [1416]
Wet Coil	.04	.04	.05	.05	.06	.06
Economizer R.A. Damper Open	.03	.04	.05	.06	.07	.08
Concentric Grille & Transition	.11	.12	.13	.15	.17	.19

NOTE: Add component resistance to duct resistance to determine total external static pressure.



AIRFLOW PERFORMANCE—10 TON [35.2 kW]—50 Hz

Air Flow CFM [L/s]	Capacity 10 Ton [35.2 kW]																										
	External Static Pressure—Inches of Water [kPa]																										
	0.1 [.02]		0.2 [.05]		0.3 [.07]		0.4 [.10]		0.5 [.12]		0.6 [.15]		0.7 [.17]		0.8 [.20]		0.9 [.22]		1.0 [.25]		1.1 [.27]		1.2 [.30]		1.3 [.32]		1.4 [.35]
RPM	W	RPM	W	RPM	W	RPM	W	RPM	W	RPM	W	RPM	W	RPM	W	RPM	W	RPM	W	RPM	W	RPM	W	RPM	W	RPM	W
2600 [1227]	—	572	776	602	816	633	858	664	901	699	948	729	1010	758	1072	816	1134	863	1258	875	1320	914	1581	943	1666		
2800 [1321]	564	839	593	884	623	929	974	684	1020	717	1069	748	1131	775	1192	804	1254	834	1316	892	1440	928	1709	958	1794		
3000 [1416]	579	924	608	972	638	1020	1069	705	1127	734	1189	763	1251	792	1313	822	1375	851	1437	880	1498	913	1752	943	1837		
3200 [1510]	603	945	630	1020	659	1095	1170	715	1245	742	1319	770	1394	797	1468	825	1543	852	1617	880	1692	—	—	—	—		
3400 [1605]	629	1114	658	1188	686	1262	1336	742	1410	769	1485	797	1559	824	1634	852	1708	879	1783	950	1811	—	—	—	—		
3600 [1699]	655	1278	684	1352	713	1426	1501	769	1576	796	1650	824	1725	851	1799	879	1874	945	1892	—	—	—	—	—	—		
3800 [1793]	684	1445	712	1519	740	1593	1667	768	1667	796	1741	823	1816	851	1890	878	1965	940	2003	—	—	—	—	—	—		
4000 [1888]	711	1607	739	1682	767	1757	1832	795	1832	823	1907	850	1981	878	2056	935	2085	985	2199	—	—	—	—	—	—		

NOTE: L- Drive left of bold line, M- Drive right of bold line.

Drive Package	L						M					
Motor H.P. [W]	3.0 [2237.1]						3.0 [2237.1]					
Blower Sheave	BK90						BK65					
Motor Sheave	1VP-44						1VP-44					
Turns Open	1	2	3	4	5	6	1	2	3	4	5	6
RPM	704	675	646	616	586	557	955	907	867	826	786	745

NOTES: 1. Factory sheave settings are shown in bold print.
2. Do not set motor sheave below one turn open.

**AIRFLOW CORRECTION FACTORS
10 TON [35.2 kW]**

ACTUAL—CFM [L/s]	2600 [1227]	2800 [1321]	3000 [1416]	3200 [1510]	3400 [1605]	3600 [1699]	3800 [1793]	4000 [1888]
TOTAL MBH	.95	.96	.97	.99	1.00	1.01	1.02	1.03
SENSIBLE MBH	.88	.91	.93	.96	.99	1.01	1.04	1.07
POWER KW	.98	.98	.99	.99	1.00	1.00	1.01	1.01

NOTES: 1. Multiply correction factor times gross performance data.
2. Resulting sensible capacity cannot exceed total capacity.

[] Designates Metric Conversions

**COMPONENT AIR RESISTANCE, IWC
10 TON [35.2 kW]**

Component	Standard Indoor Airflow—CFM [L/s]							
	2600 [1227]	2800 [1321]	3000 [1416]	3200 [1510]	3400 [1605]	3600 [1699]	3800 [1793]	4000 [1888]
Wet Coil	.05	.06	.06	.07	.07	.08	.08	.09
Economizer R.A. Damper Open	.06	.07	.08	.09	.10	.11	.12	.13
Concentric Grille & Transition	.15	.17	.19	.21	.24	.28	.33	.38

NOTE: Add component resistance to duct resistance to determine total external static pressure.



AIRFLOW PERFORMANCE—12.5 TON [44.0 kW]—50 Hz

Air Flow CFM [L/s]	Model SKKL-B151 Capacity 12.5 Ton [44.0 kW] Voltage 200-220/380-415 — 3 Phase 50 Hz																													
	External Static Pressure—Inches of Water [kPa]																													
	0.1 [0.2]	0.2 [0.05]	0.3 [0.07]	0.4 [0.10]	0.5 [0.12]	0.6 [0.15]	0.7 [0.17]	0.8 [0.20]	0.9 [0.22]	1.0 [0.25]	1.1 [0.27]	1.2 [0.30]	1.3 [0.32]	1.4 [0.35]	1.5 [0.37]	1.6 [0.40]														
3400 [1604]	—	—	—	489	1014	518	1097	546	1180	573	1265	600	1352	626	1439	650	1528	674	1618	698	1710	720	1803	741	1897	762	1993	782	2090	
3600 [1699]	—	—	—	498	1073	527	1158	555	1244	582	1331	608	1420	633	1510	657	1601	681	1694	704	1788	726	1883	747	1980	767	2078	787	2177	
3800 [1793]	—	—	—	507	1135	536	1223	563	1311	590	1401	615	1492	640	1584	665	1678	688	1773	710	1869	732	1967	753	2066	772	2166	791	2268	
4000 [1888]	—	—	488	1113	517	1201	545	1291	572	1382	598	1474	623	1567	648	1662	672	1758	695	1855	717	1954	738	2054	758	2156	778	2258	—	
4200 [1982]	—	—	498	1180	526	1271	554	1363	580	1456	606	1550	631	1646	656	1743	679	1842	701	1942	723	2043	744	2145	764	2249	783	2354	—	
4400 [2076]	—	—	508	1251	536	1344	563	1438	589	1534	615	1631	639	1729	663	1828	686	1929	708	2031	730	2135	750	2240	770	2346	789	2453	—	
4600 [2171]	—	489	1231	518	1325	545	1421	572	1517	598	1615	623	1714	648	1815	671	1917	694	2020	715	2125	736	2231	756	2338	776	2447	—	—	
4800 [2265]	—	500	1307	528	1403	555	1501	582	1600	607	1700	632	1802	656	1905	679	2009	701	2115	723	2222	743	2330	763	2440	782	2551	—	—	
5000 [2359]	482	1289	510	1386	538	1485	565	1585	591	1686	616	1789	641	1893	664	1998	687	2105	709	2213	730	2323	750	2433	769	2545	788	2659	—	—

NOTE: L-Drive left of bold line, M-Drive right of bold line.

Drive Package	L						M					
Motor H.P. [W]	5.0 [3728.5]						5.0 [3728.5]					
Blower Sheave	BK72H						BK85H					
Motor Sheave	1VP-44						1VM-65					
Turns Open	1	2	3	4	5	6	1	2	3	4	5	6
RPM	620	597	561	538	504	481	789	764	736	708	679	652

- NOTES: 1. Factory sheave settings are shown in bold type.
 2. Do not set motor sheave below minimum or maximum turns open shown.
 3. Re-adjustment of sheave required to achieve rated airflow at AHRI minimum External Static Pressure
 4. Drive data shown is for horizontal airflow with dry coil. Add component resistance (below) to duct resistance to determine total External Static Pressure.

AIRFLOW CORRECTION FACTORS 12.5 TON [44.0 kW]

ACTUAL—CFM [L/s]	3800 [1793]	4000 [1888]	4200 [1982]	4400 [2076]	4600 [2171]	4800 [2265]	5000 [2359]
TOTAL MBH	0.96	0.97	0.97	0.98	0.98	0.99	0.99
SENSIBLE MBH	0.86	0.88	0.90	0.92	0.94	0.96	0.98
POWER kW	0.99	0.99	0.99	1.00	1.00	1.00	1.00

- NOTES: 1. Multiply correction factor times gross performance data.
 2. Resulting sensible capacity cannot exceed total capacity.

[] Designates Metric Conversions

COMPONENT AIR RESISTANCE, IWC 12.5 TON [44.0 kW]

Component	Standard Indoor Airflow—CFM [L/s]											
	Resistance—Inches Water [kPa]											
	3800 [1793]	4000 [1888]	4200 [1982]	4400 [2076]	4600 [2171]	4800 [2265]	5000 [2359]					
Wet Coil	0.08 [0.02]	0.09 [0.02]	0.09 [0.02]	0.10 [0.02]	0.10 [0.02]	0.11 [0.03]	0.11 [0.03]					
Downflow	0.07 [0.02]	0.06 [0.01]	0.06 [0.01]	0.05 [0.01]	0.05 [0.01]	0.05 [0.01]	0.05 [0.01]					
Downflow Economizer R.A. Damper Open	0.12 [0.03]	0.13 [0.03]	0.14 [0.03]	0.15 [0.04]	0.16 [0.04]	0.17 [0.04]	0.18 [0.04]					
Horizontal Economizer R.A. Damper Open	0.07 [0.02]	0.07 [0.02]	0.08 [0.02]	0.08 [0.02]	0.09 [0.02]	0.10 [0.02]	0.10 [0.02]					
Concentric Grill RXRN-AD80 or RXRN-AD81 & Transition RXVMC-CJ07	0.19 [0.05]	0.21 [0.05]	0.24 [0.06]	0.27 [0.07]	0.30 [0.07]	0.33 [0.08]	0.36 [0.09]					

NOTE: Add component resistance to duct resistance to determine total external static pressure



ELECTRICAL DATA – SKKL SERIES										
		B090NL	B090NM	B090PL	B120NL	B120NM	B120PL	B151NL	B151NM	B151PL
Unit Information	Unit Operating Voltage Range	342-456	342-456	180-242	342-456	342-456	180-242	342-456	342-456	180-242
	Volts	380/415	380/415	200/220	380/415	380/415	200/220	380/415	380/415	200/220
	Minimum Circuit Ampacity	23/23	23/23	43/43	31/31	31/31	56/56	36/36	36/36	67/67
	Minimum Overcurrent Protection Device Size	30/30	30/30	50/50	35/35	35/35	70/70	40/40	40/40	75/75
	Maximum Overcurrent Protection Device Size	30/30	30/30	60/60	45/55	45/55	80/80	45/45	45/45	70/70
Compressor Motor	No.	1	1	1	1	1	1	2	2	2
	Volts	380/415	380/415	200/220	380/415	380/415	200/220	380/415	380/415	200/220
	Phase	3	3	3	3	3	3	3	3	3
	RPM	2900	2900	2900	2875	2875	2875	2900	2900	2900
	HP, Compressor 1	6	6	6	8	8	8	5 3/4	5 3/4	5 3/4
	Amps (RLA), Comp. 1	11.2/11.2	11.2/11.2	21.7/21.7	16.7/16.7	16.7/16.7	30.1/30.1	10.6/10.6	10.6/10.6	22.4/22.4
	Amps (LRA), Comp. 1	68/75	68/75	163/179	111/111	111/111	231/231	67/74	67/74	149/149
	HP, Compressor 2	—	—	—	—	—	—	5 1/4	5 1/4	5 1/4
	Amps (LLA), Comp 2	—	—	—	—	—	—	58/62	58/62	122/135
Condenser Motor	No.	1	1	1	2	2	2	2	2	2
	Volts	380/415	380/415	200/220	380/415	380/415	208/230	380/415	380/415	200/220
	Phase	1	1	1	1	1	1	1	1	1
	HP	1/2	1/2	1/2	1/3	1/3	1/3	1/2	1/2	1/2
	Amps (FLA, each)	1.5/1.5	1.5/1.5	2.3/2.3	1.4/1.4	1.4/1.4	2.4/2.4	1.5/1.5	1.5/1.5	2.3/2.3
	Amps (LRA, each)	3.1/3.1	3.1/3.1	5.6/5.6	2.4/2.4	2.4/2.4	4.7/4.7	3.1/3.1	3.1/3.1	5.6/5.6
Evaporator Fan	No.	1	1	1	1	1	1	1	1	1
	Volts	380/415	380/415	200/220	380/415	380/415	200/220	380/415	380/415	200/220
	Phase	3	3	3	3	3	3	3	3	3
	HP	3	3	3	3	3	3	5.0	5.0	5.0
	Amps (FLA, each)	7/7	7/7	13/13	7/7	7/7	13/13	10/10	10/10	18.8/18.8
	Amps (LRA, each)	38.1/38.1	38.1/38.1	74.5/74.5	38.1/38.1	38.1/38.1	74.5/74.5	41.3/41.3	41.3/41.3	82.6/82.6



GAS HEAT / ELECTRIC COOLING PACKAGE

SUPPLY AND RETURN DIMENSIONS FOR HORIZONTAL APPLICATIONS

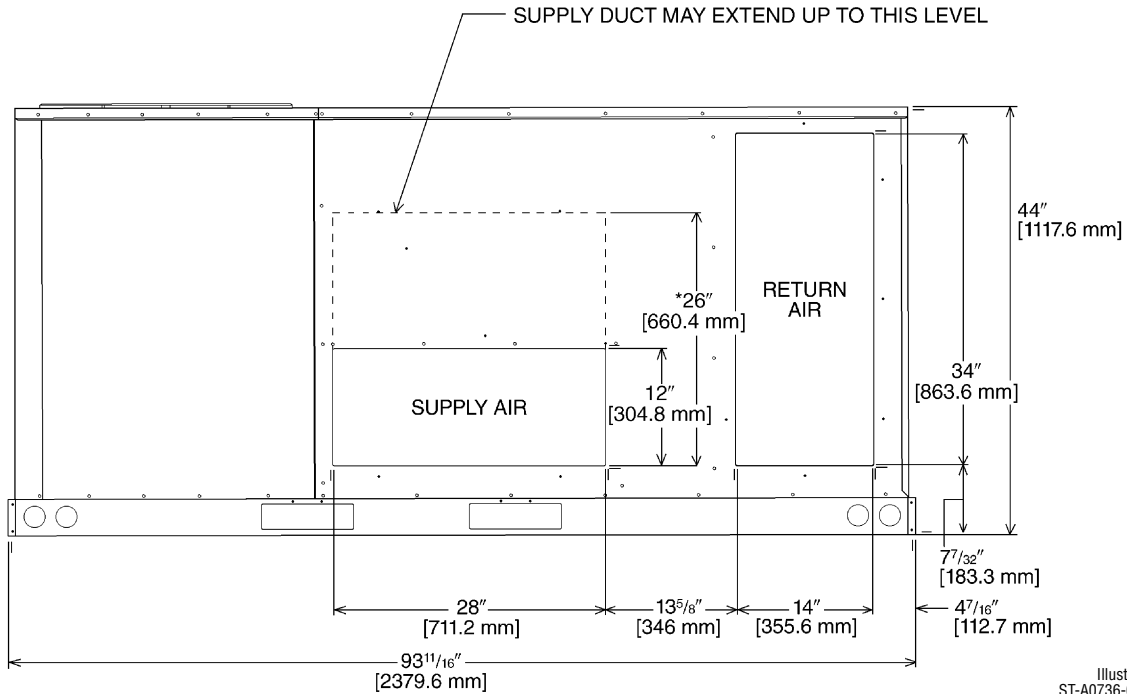

Illustration
ST-A0736-02-X1

*RECOMMENDED DUCT DIMENSIONS ARE 26"

SUPPLY AND RETURN DIMENSIONS FOR DOWNFLOW APPLICATIONS

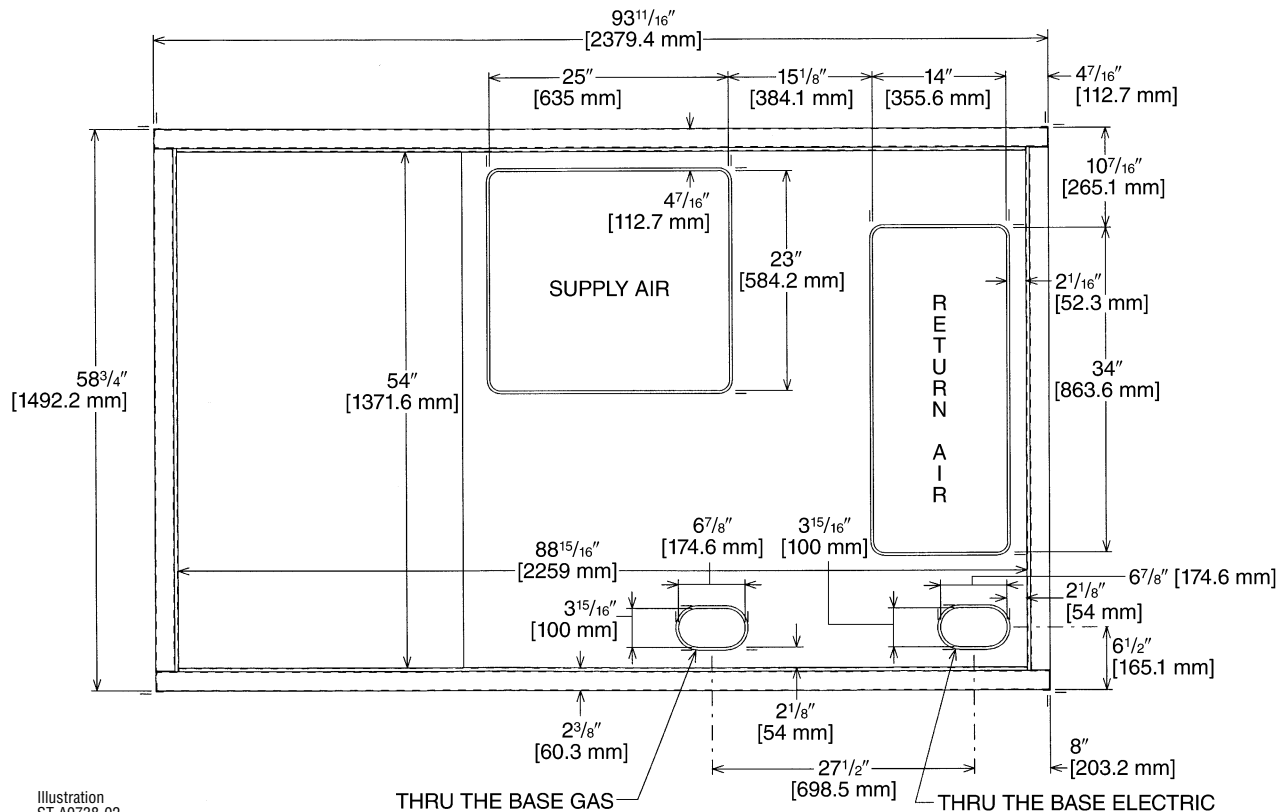

Illustration
ST-A0738-02

[] Designates Metric Conversions

GAS HEAT / ELECTRIC COOLING PACKAGE

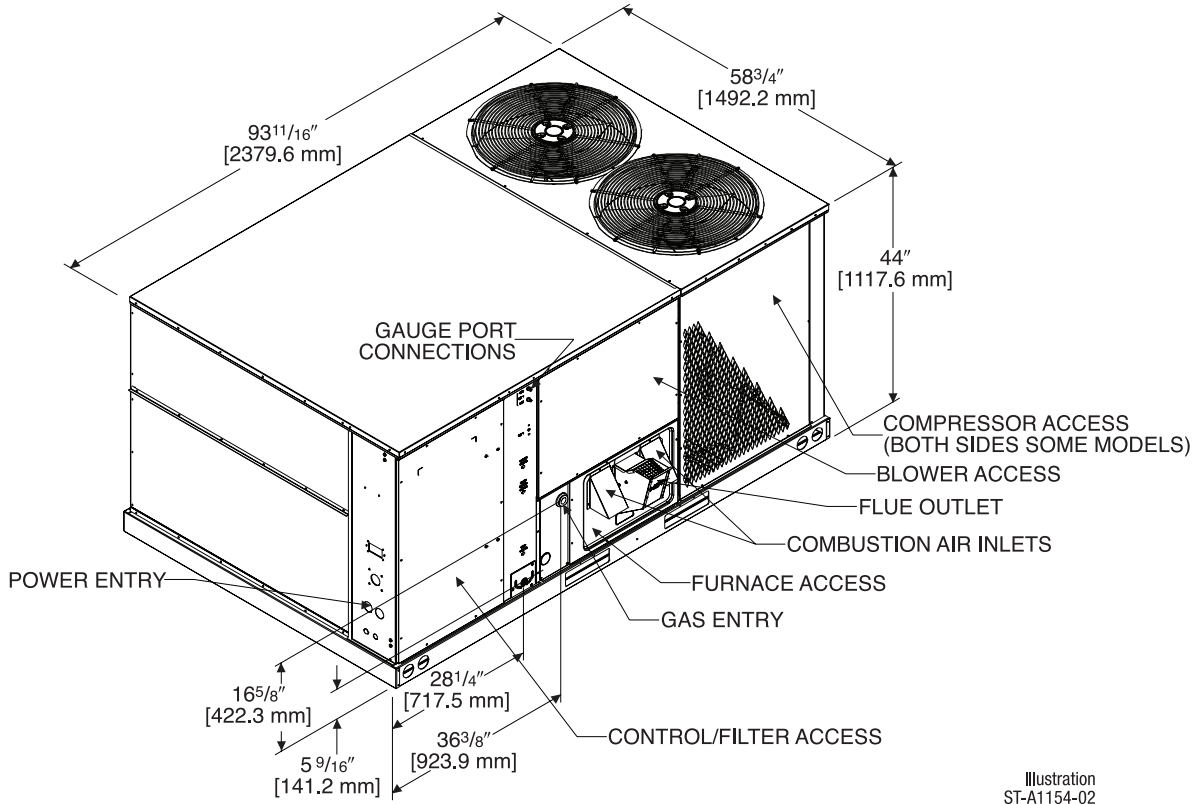

Illustration
ST-A1154-02

[] Designates Metric Conversions



WEIGHTS

Accessory	Shipping—lbs [kg]	Operating—lbs [kg]
Economizer	90 [40.82]	81 [36.70]
Power Exhaust	44 [19.96]	42 [19.05]
Fresh Air Damper (Manual)	26 [11.79]	21 [9.53]
Fresh Air Damper (Motorized)	43 [19.50]	38 [17.24]
Roof Curb 14"	90 [40.82]	85 [38.60]
Roof Curb 24"	140 [63.50]	135 [61.23]

Capacity Tons [kW]	Corner Weights by Percentage			
	A	B	C	D
7.5 [26.4]	30%	35%	14%	21%
10 [35.2]	33%	27%	17%	23%
12.5 [44.0]	44%	30%	12%	14%

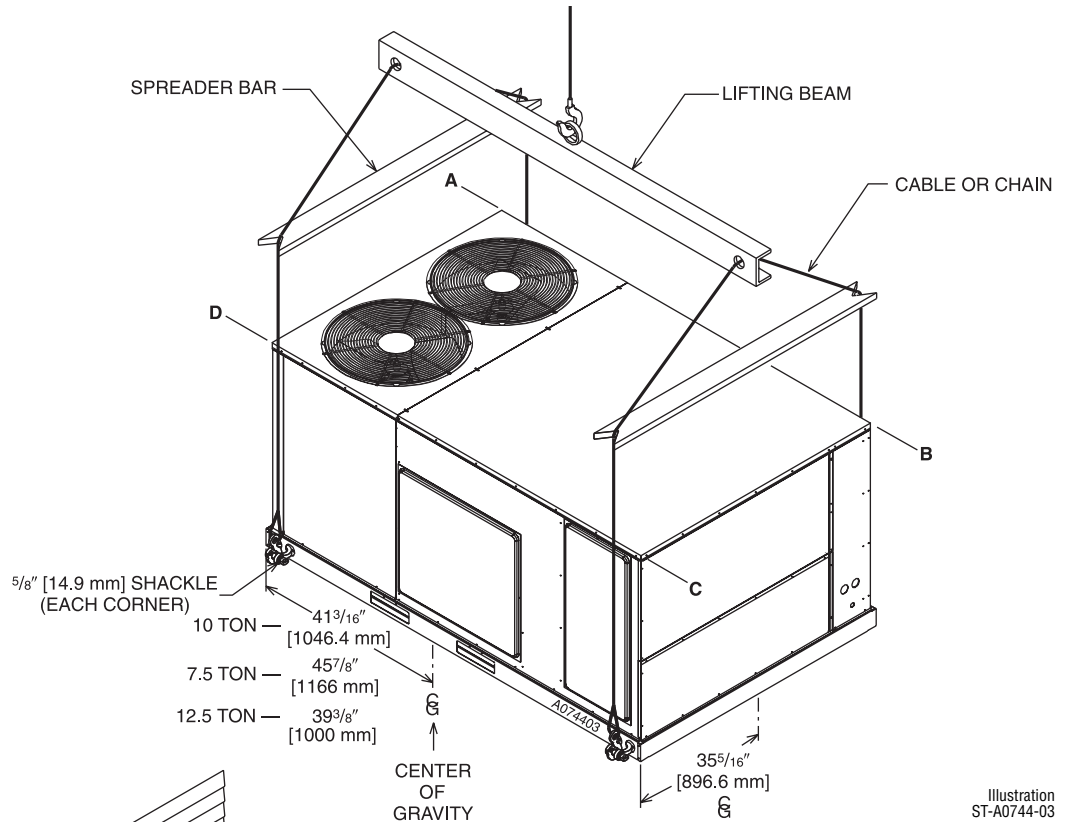
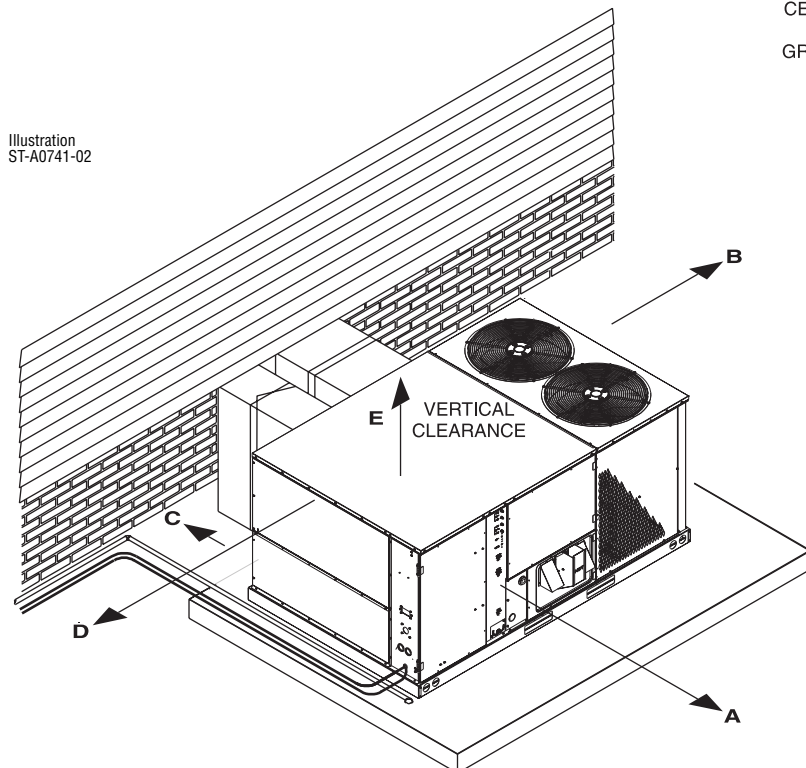

Illustration ST-A0744-03

Illustration ST-A0741-02



CLEARANCES

The following minimum clearances must be observed for proper unit performance and serviceability.

Recommended Clearance In. [mm]	Location
48 [1219]	A - Front
18 [457]	B - Condenser Coil
18 [457]	C - Duct Side
18 [457]	*D - Evaporator End
60 [1524]	E - Above
*Without Economizer. 48" [1219 mm] With Economizer	

[] Designates Metric Conversions

FIELD INSTALLED ACCESSORY EQUIPMENT

Accessory	Model Number	Shipping Weight Lbs. [kg]	Installed Weight Lbs. [kg]	Factory Installation Available?
Thermostats	See Thermostat Specification Sheet for Details (T11-001)			No
Economizer w/Single Enthalpy (Downflow)	RXRD-PDCM3	90 [40.8]	81 [36.7]	Yes
Economizer w/Single Enthalpy and Smoke Detector (Downflow)	RXRD-SDCM3	91 [41.3]	82 [37.2]	Yes
Dual Enthalpy Kit	RXRX-AV02	1 [.5]	1 [.5]	No
Horizontal Economizer w/Single Enthalpy	RXRD-RDCM3	94 [42.6]	89 [40.4]	No
Carbon Dioxide Sensor (Wall Mount)	RXRX-AR02	3 [1.4]	2 [1.0]	No
Manual Fresh Air Damper (Horizontal Return Mounted)	RXRF-JDA1	26 [11.8]	21 [9.5]	No
Manual Fresh Air Damper (Left Panel Mounted)	RXRF-KDA1	38 [17.2]	31 [14.1]	No
Motor Kit for RXRF-KDA1 (Left Panel Mounted)	RXRX-AW02	35 [15.9]	27 [12.2]	No
Motorized Fresh Air Damper (Horizontal Return Mounted)	RXRF-JDB1	43 [19.5]	38 [17.2]	No
Roofcurb, 14"	RXKG-CAE14	90 [40.8]	85 [38.5]	No
Roofcurb, 24"	RXKG-CAE24	140 [63.5]	135 [61.2]	No
Roofcurb Adapters	RXRX-CDCE50	300 [136.1]	290 [131.5]	No
	RXRX-CFCE54	325 [147.4]	315 [142.9]	No
	RXRX-CFCE56	350 [158.8]	340 [154.2]	No
	RXRX-CGCC12	450 [204.1]	410 [186.0]	No
Concentric Diffuser (Step-Down, 20" Round)	RXRN-FA65	139 [63.0]	60 [27.2]	No
Concentric Diffuser (Step-Down, 18 x 28)	RXRN-AA61	200 [90.7]	185 [83.9]	No
Concentric Diffuser (Step-Down, 18 x 32)	RXRN-AA66	247 [112.0]	227 [103.0]	No
Concentric Diffuser (Flush, 20" Round)	RXRN-FA75	54 [24.4]	42 [19.0]	No
Concentric Diffuser (Flush, 18 x 28)	RXRN-AA71	170 [77.1]	155 [70.3]	No
Concentric Diffuser (Flush, 18 x 32)	RXRN-AA76	176 [79.8]	161 [73.0]	No
Downflow Transition (Rect. to 20" Round)	RXMC-CD04 ①	15 [6.8]	13 [5.9]	No
Downflow Transition (Rect. to Rect., 18 x 28)	RXMC-CE05 ②	18 [8.2]	16 [7.3]	No
Downflow Transition (Rect. to Rect., 18 x 32)	RXMC-CF06 ③	20 [9.1]	18 [8.2]	No
Compressor Time-Delay Relay Kit	RXMD-A04	2 [1.0]	1 [.5]	No
Low-Ambient Control Kit (1 Per Compressor)	RXRZ-C02	3 [1.4]	2 [1.0]	Yes
Freeze-Stat Kit	RXRX-AM01	1 [.5]	0.5 [.2]	Yes
Outdoor Coil Louver Kit	RXRX-AAD02A (7 ¹ / ₂ -12 ¹ / ₂ Ton)	29 [11.3]	26 [11.8]	Yes
Unwired Convenience Outlet	RXRX-AN01	2 [1.0]	1.5 [.7]	Yes
Unfused Service Disconnect	RXRX-AP01	10 [4.5]	9 [4.1]	Yes

NOTES: ① Used with RXRN-FA65 and RXRN-FA75 concentric diffusers.

② Used with RXRN-AA61 and RXRN-AA71 concentric diffusers.

③ Used with RXRN-AA66 and RXRN-AA76 concentric diffusers.

NOTICE: Please refer to conversion kit index provided with the unit for LP conversion kit.

[] Designates Metric Conversions

THERMOSTATS

100-Series *
Non-Programmable

200-Series *
Programmable

300-Series *
Deluxe
Programmable

400-Series *
Special Applications/
Programmable

500-Series *
Communicating/
Programmable

Brand	Unique Model Number Prefix	Descriptor (3 Characters)	Series (3 Characters)	System (2 Characters)	Type (2 Characters)
RHC	-	TST	101	GE	MS
RHC=Rheem		TST=Thermostat	100=Non-Programmable 200=Programmable 300=Deluxe Programmable 400=Special Applications/ Programmable 500=Communicating/ Programmable	GE=Gas/Oil/Electric HP=Heat Pump MD=Modulating Furnace DF=Dual Fuel UN=Universal AC/HP/GE CM=Communicating	SS=Single-Stage MS=Multi-Stage

* Photos are representative. Actual models may vary.

For detailed thermostat match-up information, see specification sheet form number T11-001.

ECONOMIZER FOR DOWNFLOW DUCT INSTALLATION

Use to Select Factory Installed Options Only

RXRD-PDCM3—Single Enthalpy (Outdoor) and RXRD-SDCM3 Single Enthalpy with Smoke Detector

RRRX-AV02—Dual Enthalpy Upgrade Kit

RRRX-AR02—Optional Wall-Mounted CO₂ Sensor

- Features **Honeywell** Controls
- Available Factory Installed or Field Accessory
- Gear Driven Direct Drive Actuator
- Fully Modulating (0-100%)
- Low Leakage Dampers
- Slip-In Design for Easy Installation
- Plug-In Polarized 12-pin Electrical Connections
- Pre-Configured—No Field Adjustments Necessary
- Standard Barometric Relief Damper
- Single Enthalpy with Dual Enthalpy Upgrade Kit Available
- CO₂ Input Sensor Available
- Field Assembled Hood Ships with Economizer
- Economizer Ships Complete for Downflow Duct Application.
- Optional Remote Minimum Position Potentiometer (Honeywell #S963B1128) is Available from Prostock.
- Prewired for Smoke Detector

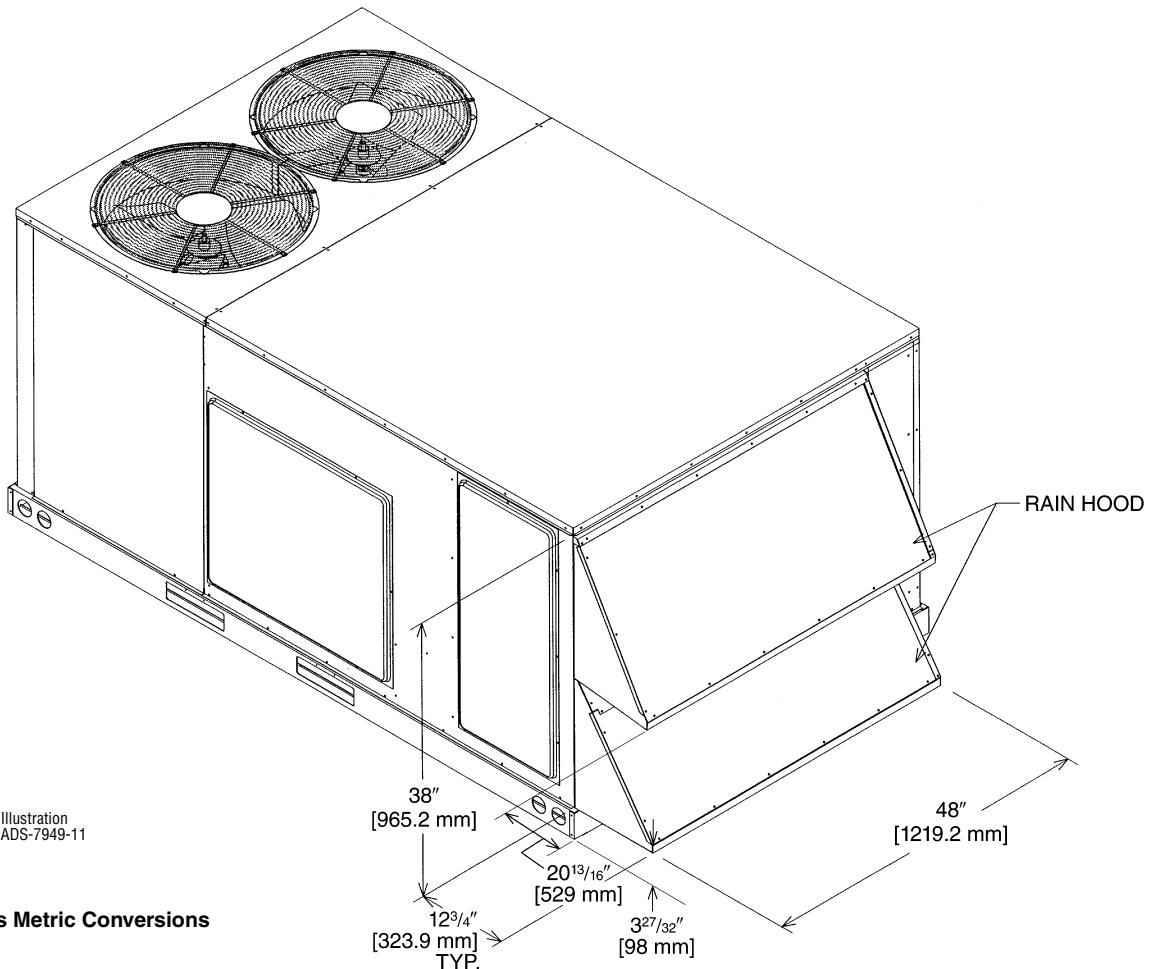
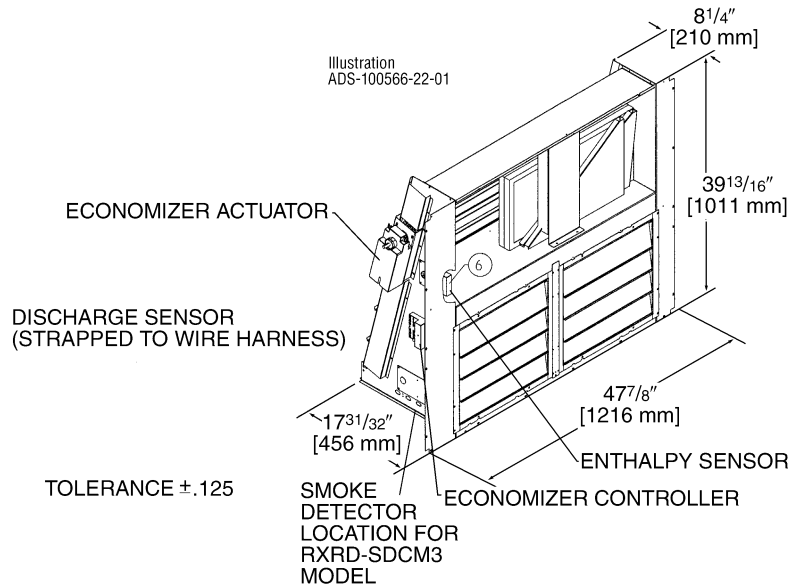

[] Designates Metric Conversions

ECONOMIZER FOR HORIZONTAL DUCT INSTALLATION

Field Installed Only

RXRD-RDCM3—Single Enthalpy (Outdoor)

RXXR-AV02—Dual Enthalpy Upgrade Kit

RXXR-AR02—Wall-mounted CO₂ Sensor

- Features **Honeywell** Controls
- Available as a Field Installed Accessory Only
- Gear Driven Direct Drive Actuator
- Fully Modulating (0-100%)
- Low Leakage Dampers
- Slip-In Design for Easy Installation
- Plug-In Polarized 12-pin Electrical Connections
- Pre-Configured—No Field Adjustments Necessary
- Standard Barometric Relief Damper
- Single Enthalpy with Dual Enthalpy Upgrade Kit Available
- CO₂ Input Sensor Available
- Field Assembled Hood Ships with Economizer
- Economizer Ships Complete for Horizontal Duct Application
- Optional Remote Minimum Position Potentiometer (Honeywell #S963B1128) is Available from Prostock

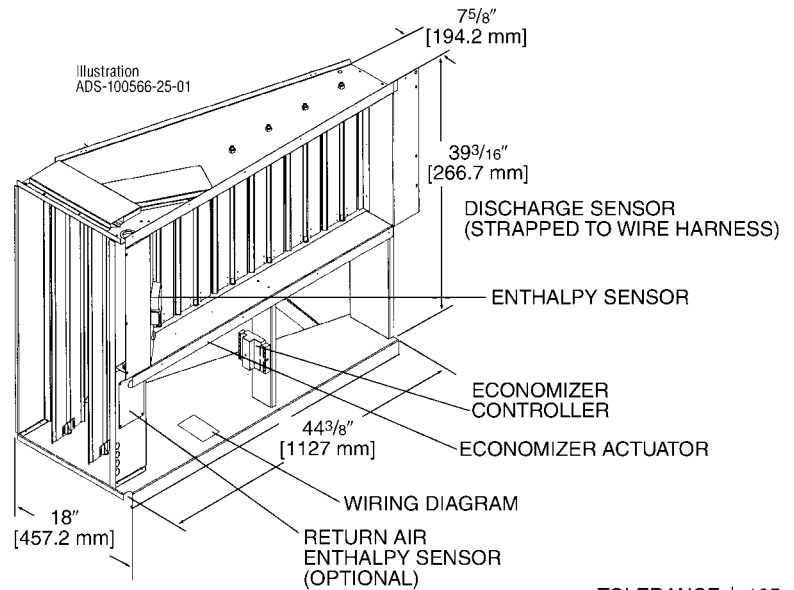

TOLERANCE ± .125

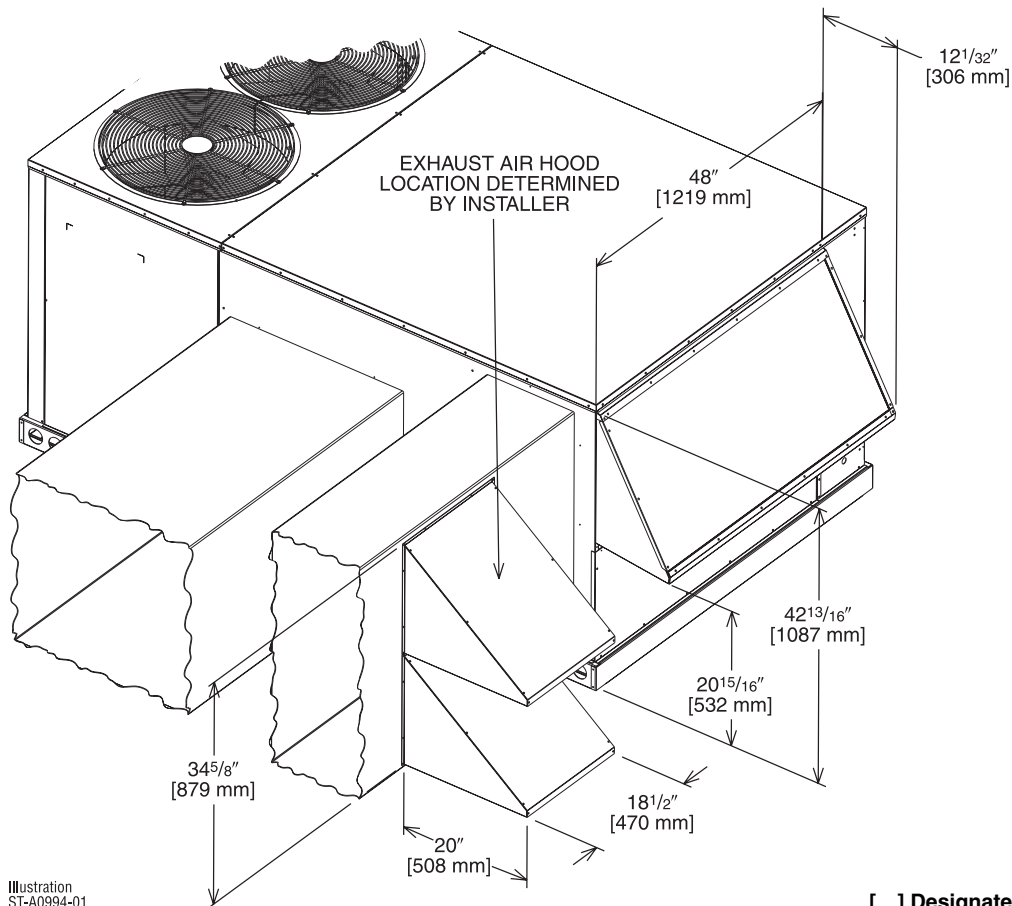

[] Designates Metric Conversions

FRESH AIR DAMPER

**MOTORIZED DAMPER KIT
RXRX-AW02
(Motor Kit for RXRF-KDA1)**

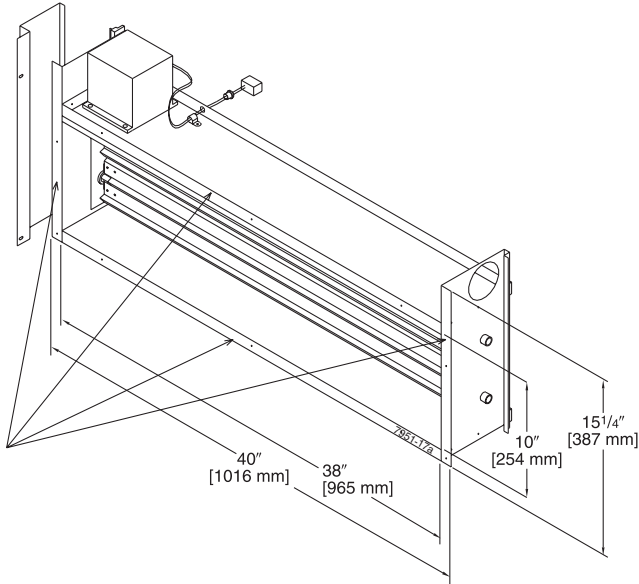

Illustration
ST-7951-17

[] Designates Metric Conversions

**RXRF-KDA1 (Manual)
DOWNFLOW OR
HORIZONTAL APPLICATION**

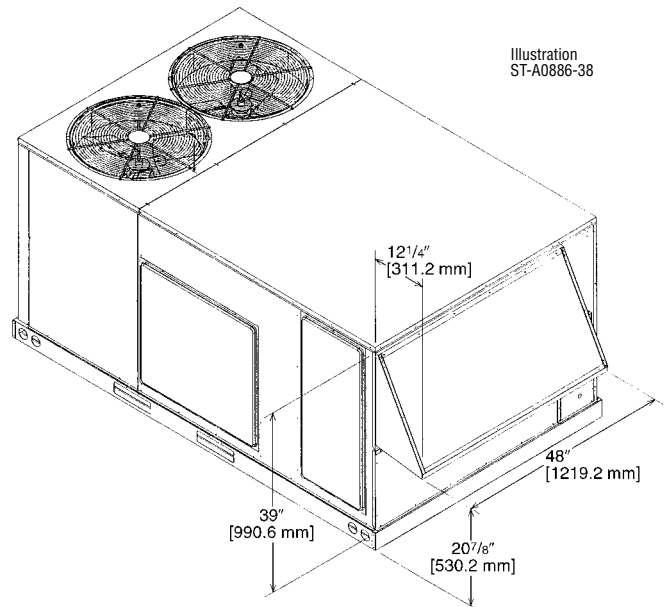

Illustration
ST-A0886-38

FRESH AIR DAMPER (Cont.)

RXRF-JDA1 (Manual)
RXRF-JDB1 (Motorized)

DOWNFLOW APPLICATION

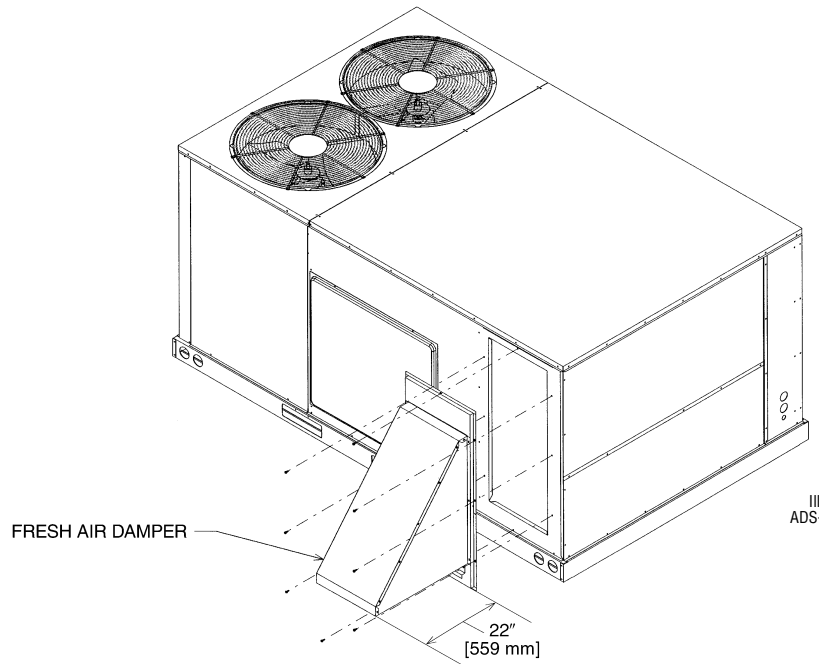
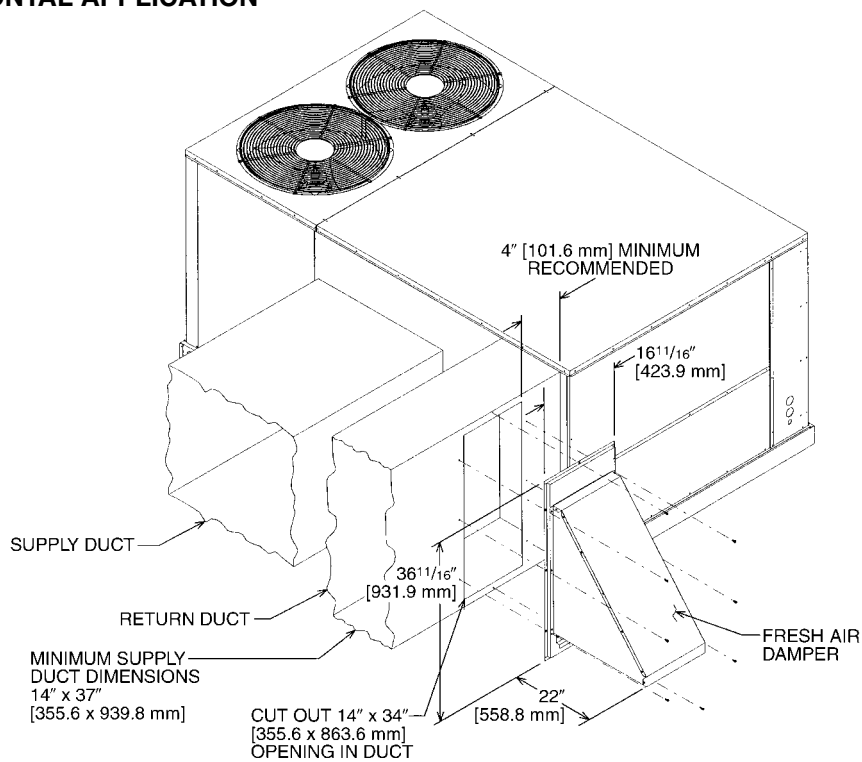

Illustration
ADS-7937-58

HORIZONTAL APPLICATION

Illustration
ST-A0901-01



[] Designates Metric Conversions

ROOFCURBS (Full Perimeter)

- Rheem's roofcurb design can be utilized on all 7.5, 10 & 12.5 ton [26.4, 35.2 and 44.0 kW] SKKL- models.
- Two available heights (14" [356 mm] and 24" [610 mm]) for ALL models.
- Quick assembly corners for simple and fast assembly.
- Opening provided in bottom pan to match the "Thru the Curb" electrical connection opening provided on the unit base pan.
- 1" [25 mm] x 4" [102 mm] Nailer provided.
- Insulating panels not required because of insulated outdoor base pan.
- Sealing gasket (40' [12.2 m]) provided with Roofcurb.
- Packaged for easy field assembly.

Roofcurb Model	Height of Curb
RXKG-CAE14	14" [356 mm]
RXKG-CAE24	24" [610 mm]

ROOFCURB INSTALLATION

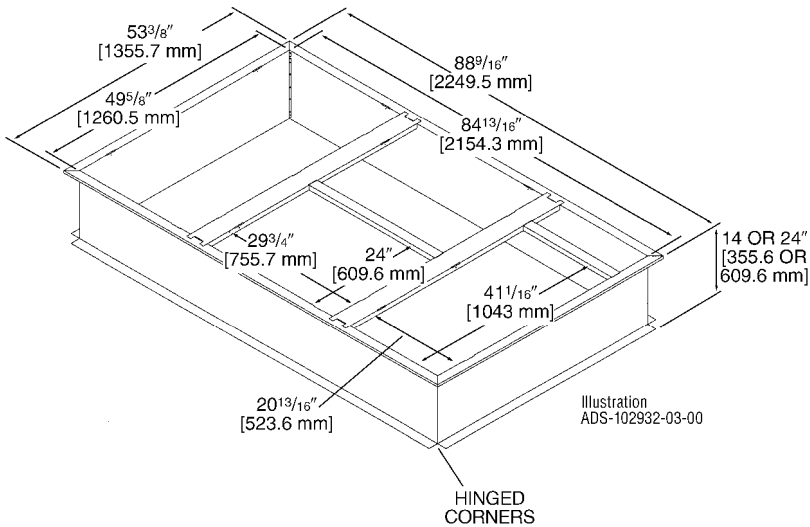

TYPICAL INSTALLATION

Illustration ST-A0743-02

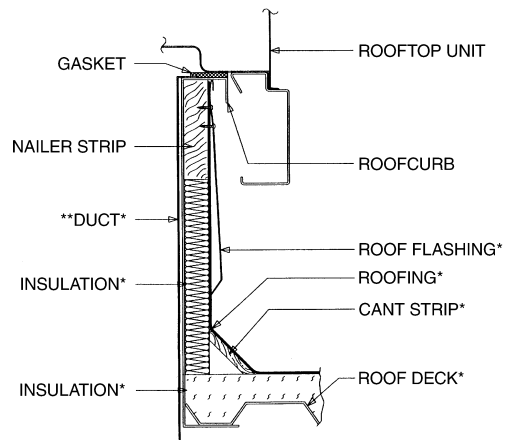
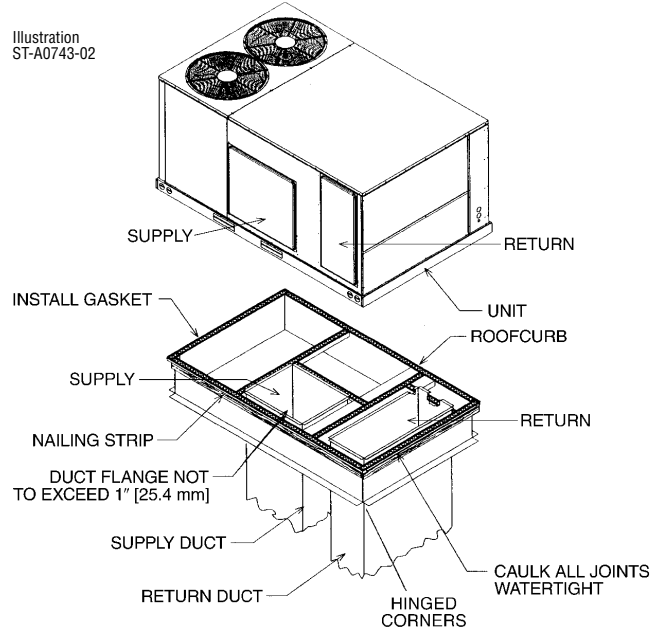

*BY CONTRACTOR

**FOR INSTALLATION OF DUCT AS SHOWN, USE RECOMMENDED DUCT SIZES FROM ROOFCURB INSTALLATION INSTRUCTIONS. FOR DUCT FLANGE ATTACHMENT TO UNIT, SEE UNIT INSTALLATION INSTRUCTIONS FOR RECOMMENDED DUCT SIZES.

Illustration ST-A0743-02

[] Designates Metric Conversions

ROOFCURB ADAPTERS

OLD MODELS	OLD ROOFCURB	ROOFCURB ADAPTER	NEW MODELS (All Share Common Cabinet)
(-)RCF, (-)REF-075/076 (-)RGF-150075, (-)RGF-131076 (-)RGF-201076	RXRK-E50	RXRX-CDCE50	SKKL- B090 SKKL- B120 SKKL- B151
(-)RGF-200075 (-)RGG, (-)REG, (-)RCG-075 (-)RGF, (-)REF, (-)RCF-085 (-)RGF, (-)REF, (-)RCF-100 (-)RGG, (-)REG, (-)RCG-100	RXRK-E54	RXRX-CFCE54	
(-)RGF, (-)REF, (-)RCF-125	RXRK-E56	RXRX-CFCE56	
(-)PDC-075 (-)PDC-100/101	RXPK-C12	RXRX-CGCC12	

NOTE: Ductwork modifications may be necessary if the capacity and/or indoor airflow rate of replacement unit is not equivalent to that of the unit being replaced. SKKL-B090, SKKL-B120 and SKKL-B151 fit on the same curb as the RKKB-B090, RKKB-A120 and RKKB-A151, RKMB-B090, RKMB-A120 and RKMB-A151, RKNB-B090 and RKNB-A120.

ROOFCURB ADAPTERS (Cont.)

RXRX-CDCE50

Illustration
ADS-7952-02
Sheet 2

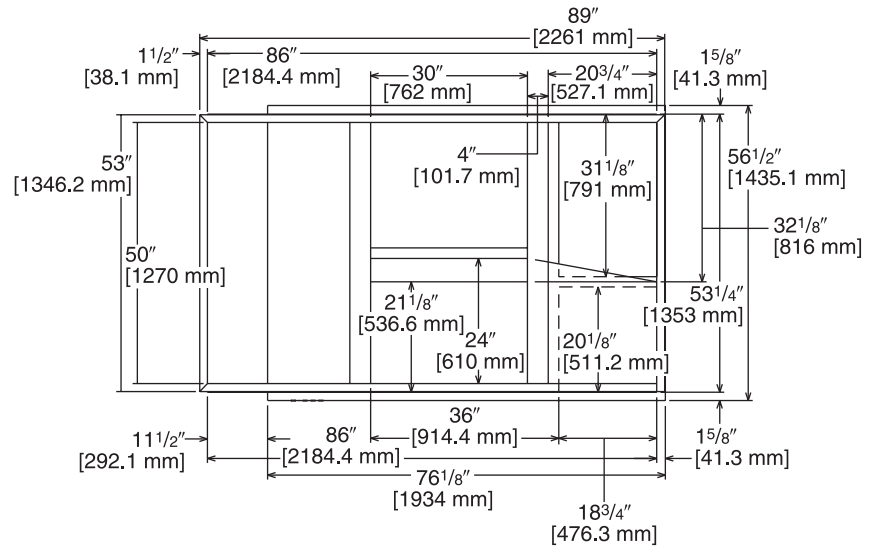

TOP VIEW

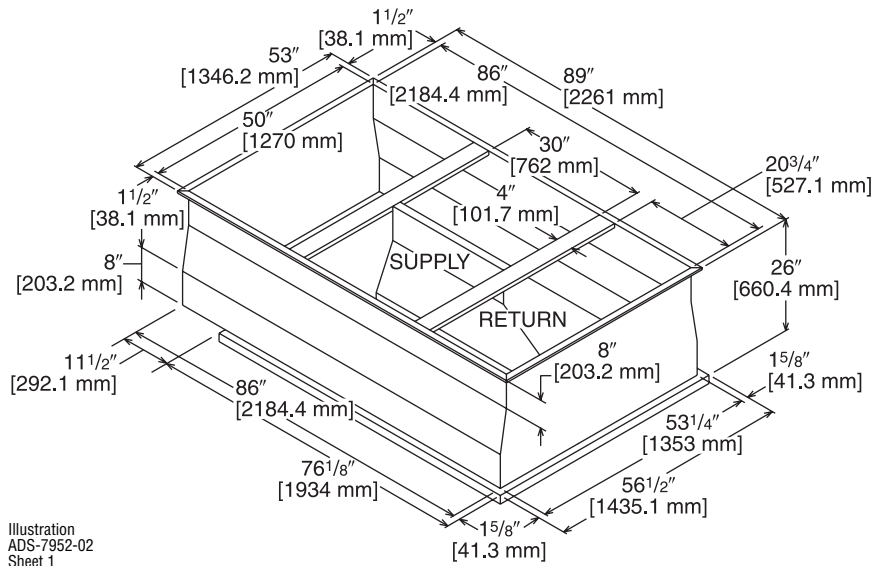

Illustration
ADS-7952-02
Sheet 1

[] Designates Metric Conversions

ROOFCURB ADAPTERS (Cont.)

RXXR-CFCE54

Illustration
ADS-7952-01
Sheet 2

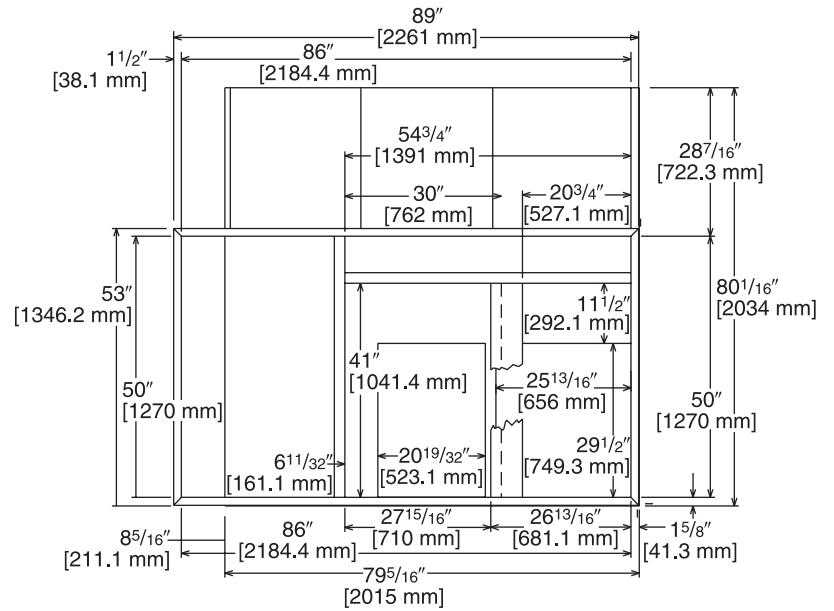

TOP VIEW

Illustration
ADS-7952-01
Sheet 1

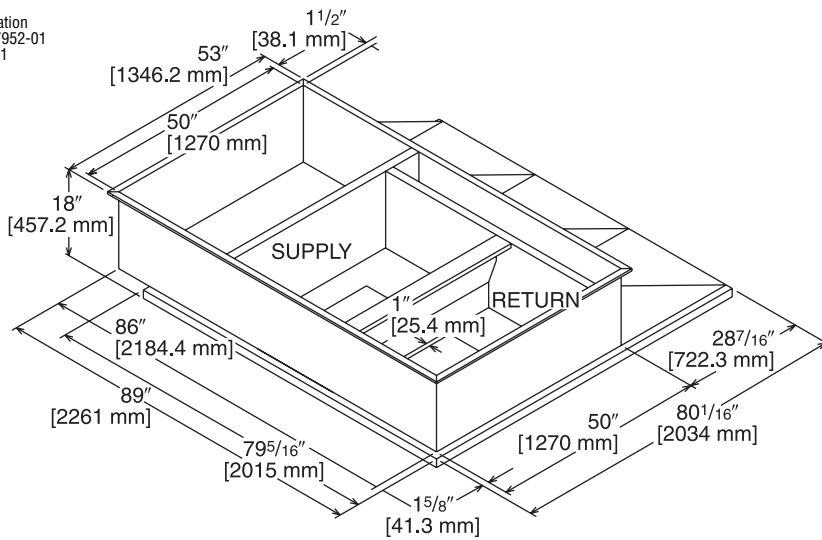

[] Designates Metric Conversions

ROOFCURB ADAPTERS (Cont.)

RXRX-CFCE56

Illustration
ADS-7952-03
Sheet 2

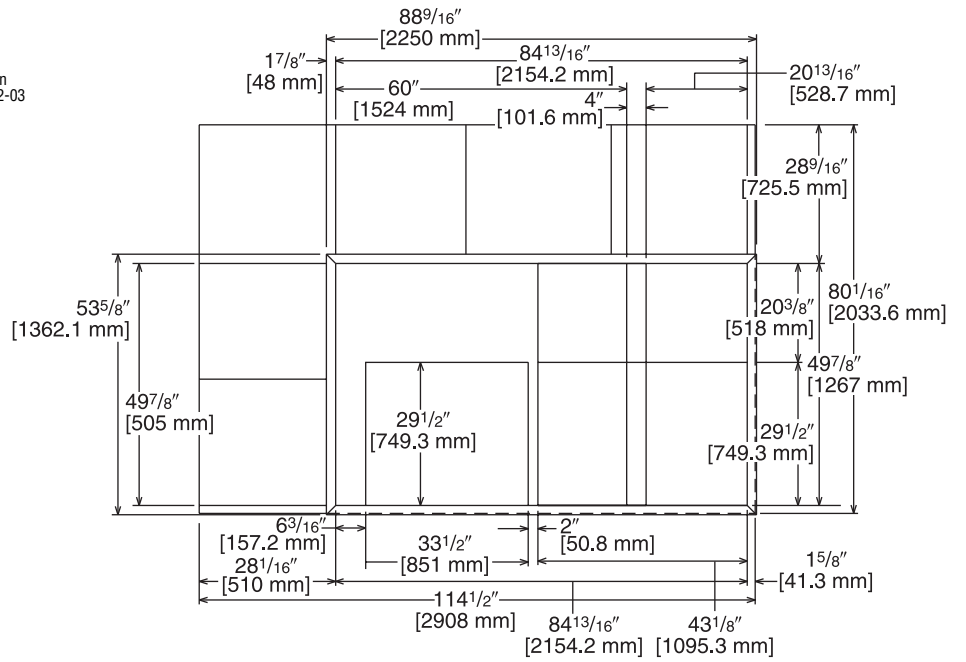

TOP VIEW

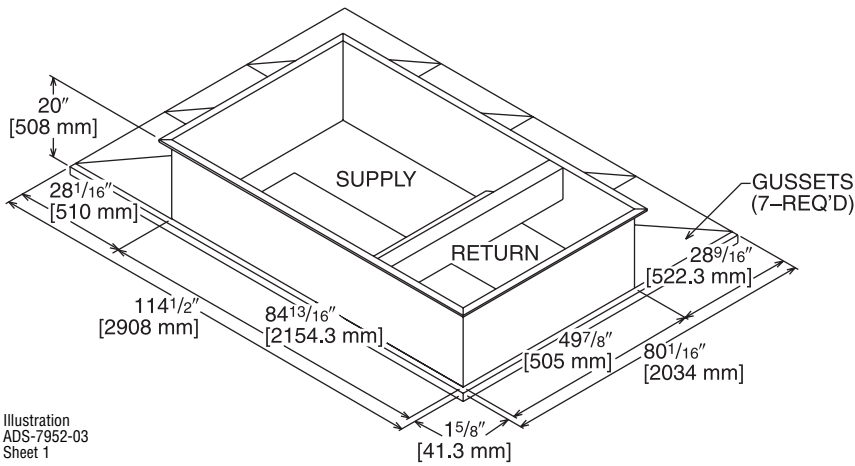

Illustration
ADS-7952-03
Sheet 1

[] Designates Metric Conversions

ROOFCURB ADAPTERS (Cont.)

RXRX-CGCC12

Illustration
ADS-7952-04
Sheet 2

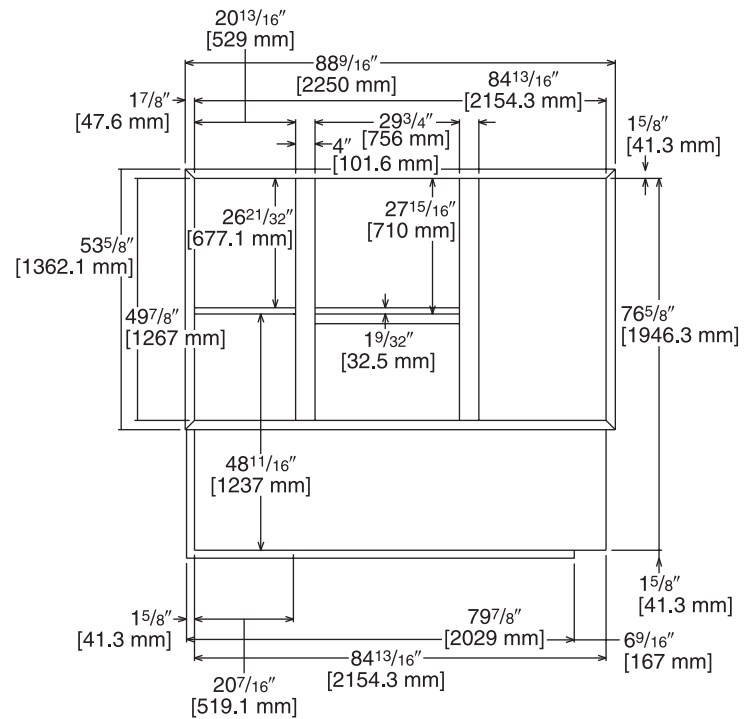

TOP VIEW

Illustration
ADS-7952-04
Sheet 1

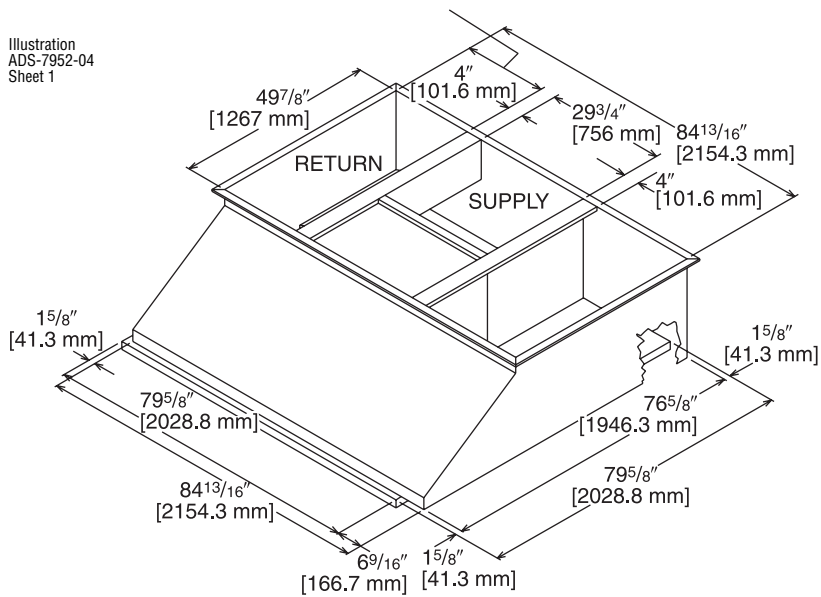

[] Designates Metric Conversions

CONCENTRIC DIFFUSER APPLICATION

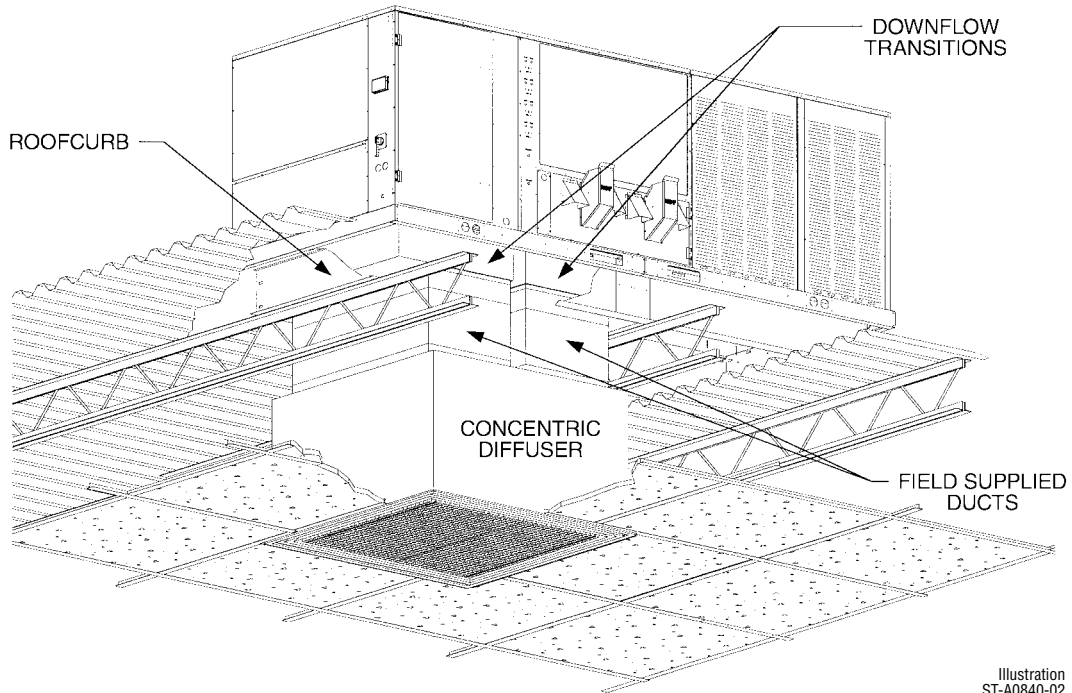

Illustration
ST-A0840-02

DOWNFLOW TRANSITION DRAWINGS

RXMC-CE05

- Used with RXRN-AA61 or RXRN-AA71 Concentric Diffusers.

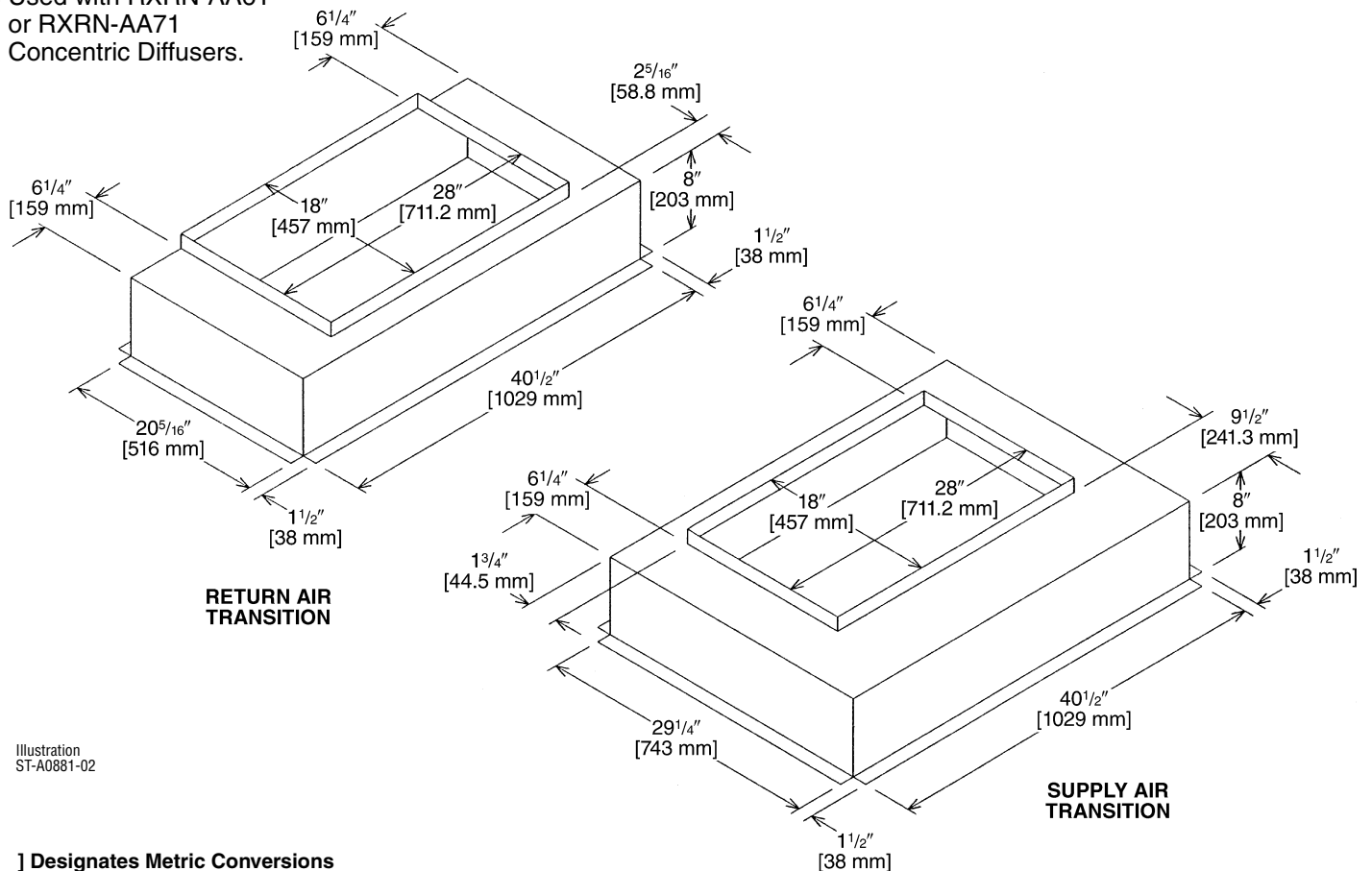

Illustration
ST-A0881-02

[] Designates Metric Conversions

DOWNFLOW TRANSITION DRAWINGS

RXMC-CF06

- Used with RXRN-AA66 or RXRN-AA76 Concentric Diffusers.

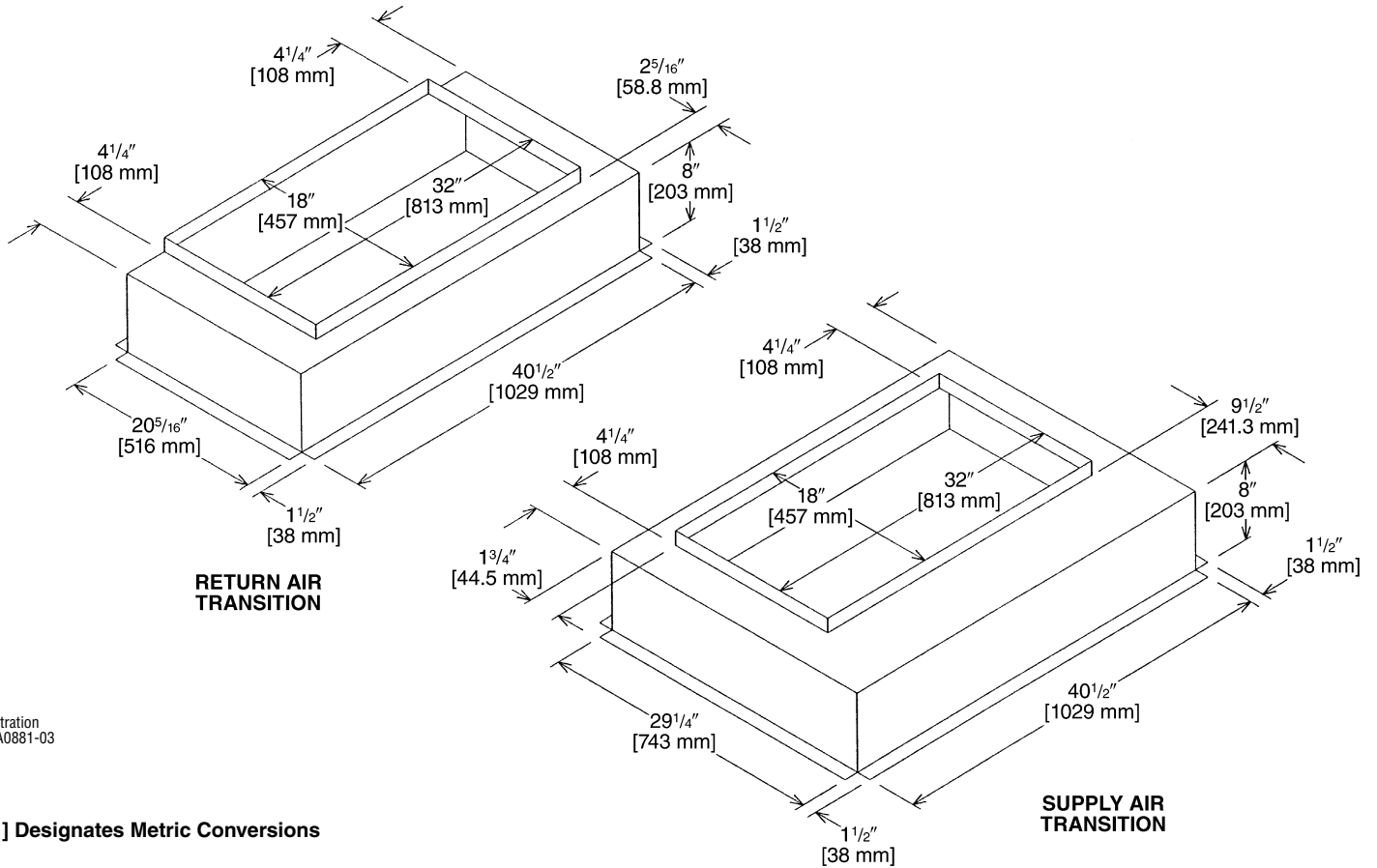

Illustration
ST-A0881-03

[] Designates Metric Conversions

DOWNFLOW TRANSITION DRAWINGS

RXMC-CD04

- Used with RXRN-FA65 or RXRN-FA75 Concentric Diffusers.

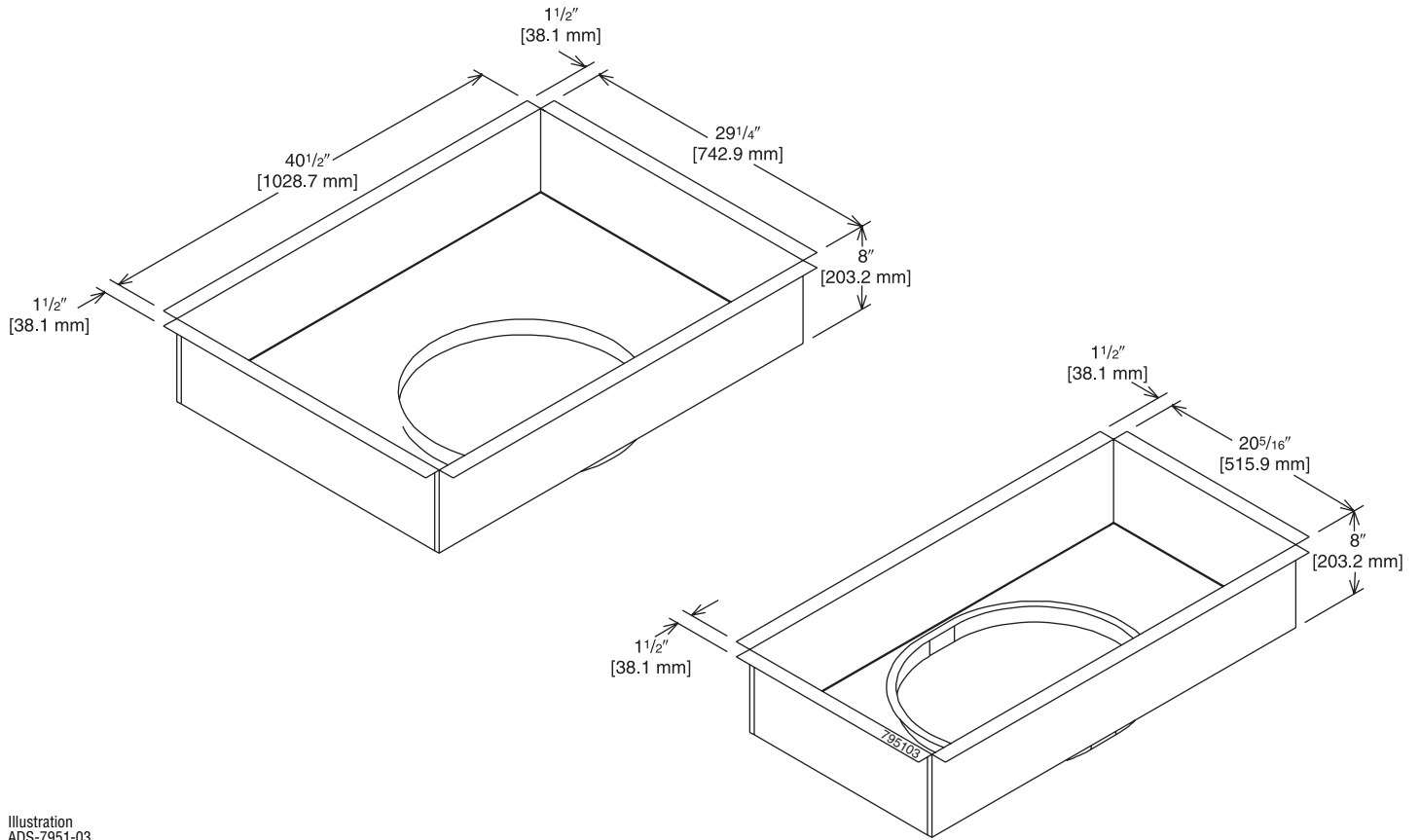

Illustration
ADS-7951-03

[] Designates Metric Conversions

CONCENTRIC DIFFUSER—STEP DOWN

RXRN-FA65 (7.5 Ton [26.4 kW] Models)

For Use With Downflow Transition (RXMC-CD04)
and 20" [508 mm] Round Supply and Return Ducts

- All aluminum diffuser with aluminum return air eggcrate.
- Built-in anti-sweat gasket.
- Molded fiberglass supports.
- Built-in hanging supports.
- Diffuser box constructed of sheetmetal insulated with 1" [25.4 mm] 1.5 lbs. [.7 kg] duct liner.

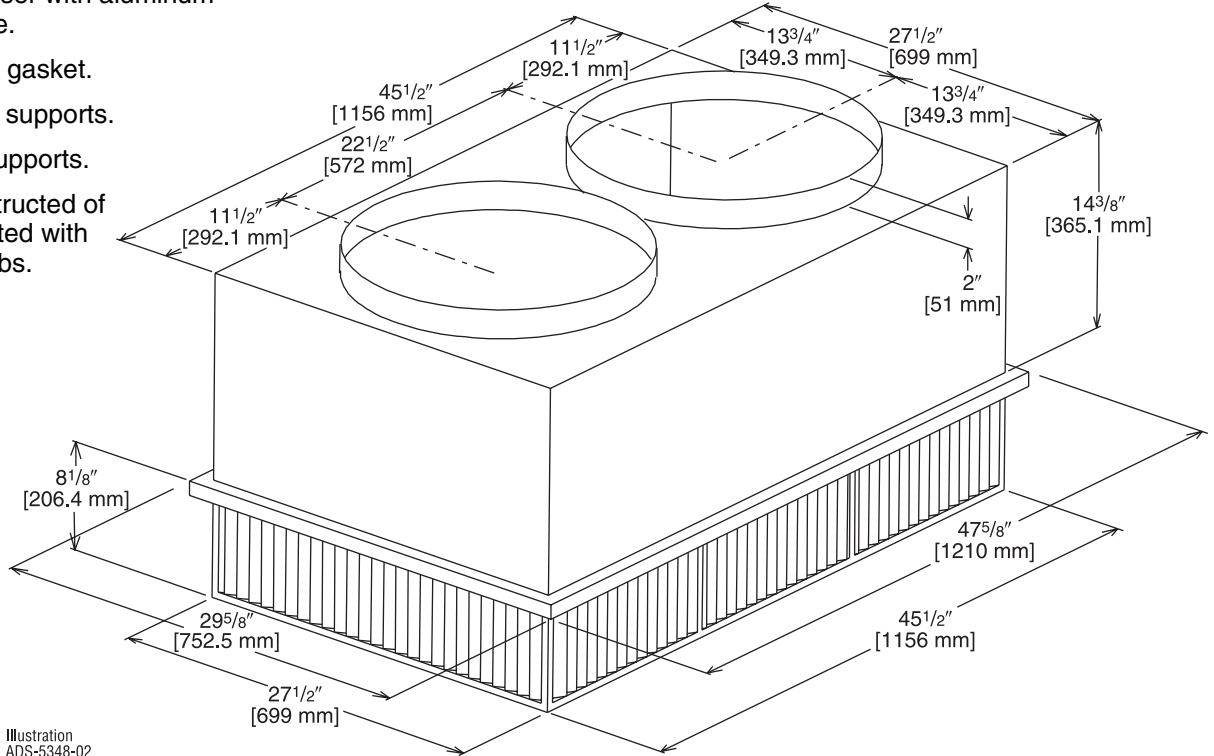

Illustration
ADS-5348-02

ENGINEERING DATA^①

Model No.	Flow Rate CFM [L/s]	Static Pressure in. w.c. [kPa]	Throw ^{② ③} Feet [m]	Neck Velocity fpm [m/s]	Noise Level ^④ (dba)
RXRN-FA65	2600 [1227]	0.17 [0.042]	24-29 [7.3-8.8]	669 [3.4]	20
	2800 [1321]	0.20 [0.050]	25-30 [7.6-9.1]	720 [3.7]	25
	3000 [1416]	0.25 [0.062]	27-33 [8.2-10.1]	772 [3.9]	25
	3200 [1510]	0.31 [0.077]	28-35 [8.5-10.7]	823 [4.2]	25
	3400 [1604]	0.37 [0.092]	30-37 [9.1-11.3]	874 [4.4]	30

NOTES: ① All data is based on the air diffusion council guidelines.

② Throw data is based on 75 FPM Terminal Velocities using isothermal air.

③ Throw is based on diffuser blades being directed in a straight pattern.

④ Actual noise levels may vary due to duct design and do not include transmitted unit noise.
Adequate duct attenuation must be provided to reduce sound output from the unit.

[] Designates Metric Conversions

CONCENTRIC DIFFUSER—STEP DOWN 18" x 28" [457.2 x 711.2 mm]

RXRN-AA61 (10 Ton [35.2] Models)

For Use With Downflow Transition (RXMC-CE05)
and 18" x 28" [457.2 x 711.2 mm]
Supply and Return Ducts

- All aluminum diffuser with aluminum return air eggcrate.
- Built-in anti-sweat gasket.
- Molded fiberglass supports.
- Built-in hanging supports.
- Diffuser box constructed of sheetmetal insulated with 1" [25.4 mm] 1.5 lbs. [.7 kg] duct liner.
- Double deflection diffuser with the blades secured by spring steel.

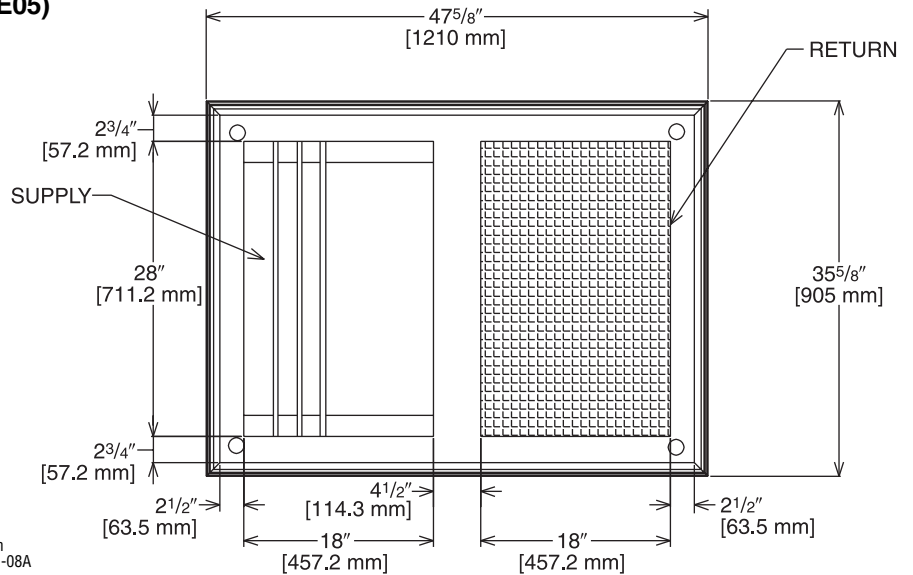

Illustration
ADS-7951-08A

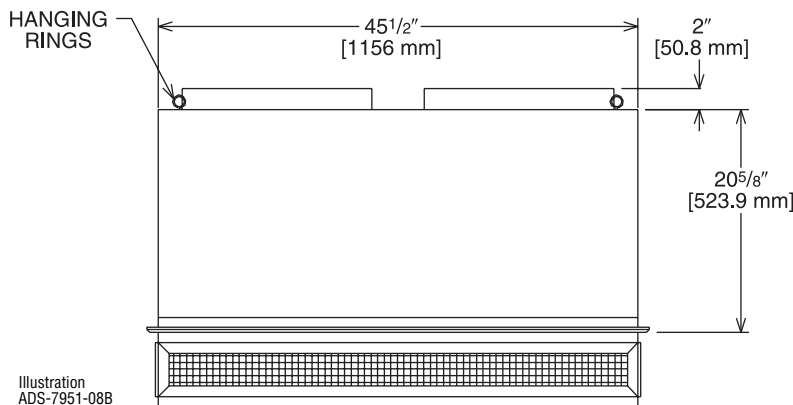

Illustration
ADS-7951-08B

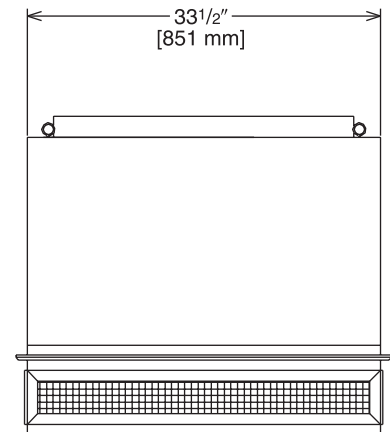

Illustration
ADS-7951-08C

ENGINEERING DATA^①

Model No.	Flow Rate CFM [L/s]	Static Pressure in w.c. [kPa]	Throw ^{② ③} Feet [m]	Neck Velocity fpm [m/s]	Noise Level ^④ (dbA)
RXRN-AA61	3600 [1699]	0.17 [0.042]	25-33 [7.6-10.1]	851 [4.3]	30
	3800 [1793]	0.18 [0.045]	27-35 [8.2-10.7]	898 [4.6]	30
	4000 [1888]	0.21 [0.052]	29-37 [8.8-11.3]	946 [4.8]	30
	4200 [1982]	0.24 [0.060]	32-40 [9.8-12.2]	993 [5.0]	30
	4400 [2076]	0.27 [0.067]	34-42 [10.4-12.8]	1040 [5.3]	30

NOTES: ① All data is based on the air diffusion council guidelines.

② Throw data is based on 75 FPM Terminal Velocities using isothermal air.

③ Throw is based on diffuser blades being directed in a straight pattern.

④ Actual noise levels may vary due to duct design and do not include transmitted unit noise.

Adequate duct attenuation must be provided to reduce sound output from the unit.

[] Designates Metric Conversions

FLUSH MOUNT CONCENTRIC DIFFUSER—FLUSH

RXRN-FA75 (7.5 Ton [26.4 kW] Models)

For Use With Downflow Transition (RXMC-CD04)
and 20" [508 mm] Round Supply and Return Ducts

- All aluminum diffuser with aluminum return air eggcrate.
- Built-in anti-sweat gasket.
- Molded fiberglass supports.
- Built-in hanging supports.
- Diffuser box constructed of sheetmetal insulated with 1" [25.4 mm] 1.5 lbs. [.7 kg] duct liner.

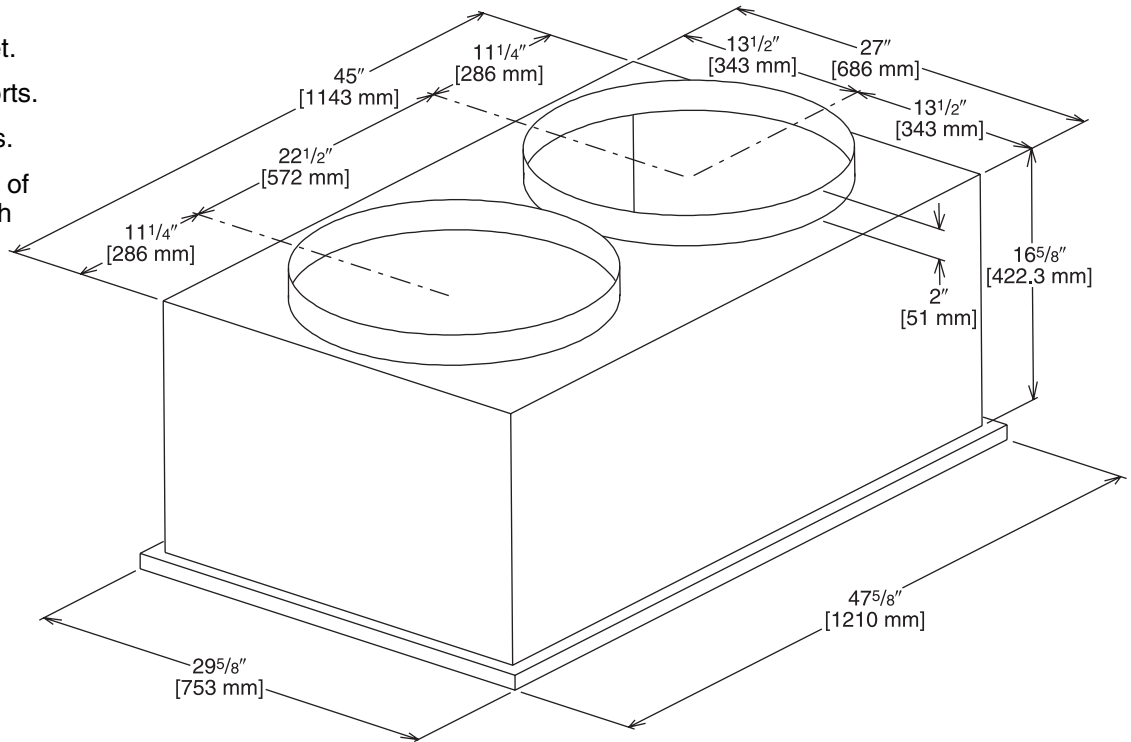

Illustration
ADS-5348-04

ENGINEERING DATA^①

Model No.	Flow Rate CFM [L/s]	Static Pressure in. w.c. [kPa]	Throw ^{② ③} Feet [m]	Neck Velocity fpm [m/s]	Noise Level ^④ (dba)
RXRN-FA75	2600 [1227]	.17 [0.042]	19-24 [5.8-7.3]	663 [3.4]	30
	2800 [1321]	.20 [0.050]	20-28 [6.1-8.5]	714 [3.6]	35
	3000 [1416]	.25 [0.062]	21-29 [6.4-8.8]	765 [3.9]	35
	3200 [1510]	.31 [0.077]	22-29 [6.7-8.8]	816 [4.1]	40
	3400 [1604]	.37 [0.092]	22-30 [6.7-9.1]	867 [4.4]	40

NOTES: ① All data is based on the air diffusion council guidelines.

② Throw data is based on 75 FPM Terminal Velocities using isothermal air.

③ Throw is based on diffuser blades being directed in a straight pattern.

④ Actual noise levels may vary due to duct design and do not include transmitted unit noise.
Adequate duct attenuation must be provided to reduce sound output from the unit.

[] Designates Metric Conversions

CONCENTRIC DIFFUSER—FLUSH and 18" x 28" [457.2 x 711.2 mm]

RXRN-AA71 (10 Ton [35.2] Models)

For Use With Downflow Transition (RXMC-CE05)
and 18" x 28" [457.2 x 711.2 mm]
Supply and Return Ducts

- All aluminum diffuser with aluminum return air eggcrate.
- Built-in anti-sweat gasket.
- Molded fiberglass supports.
- Built-in hanging supports.
- Diffuser box constructed of sheetmetal insulated with 1" [25.4 mm] 1.5 lbs. [.7 kg] duct liner.

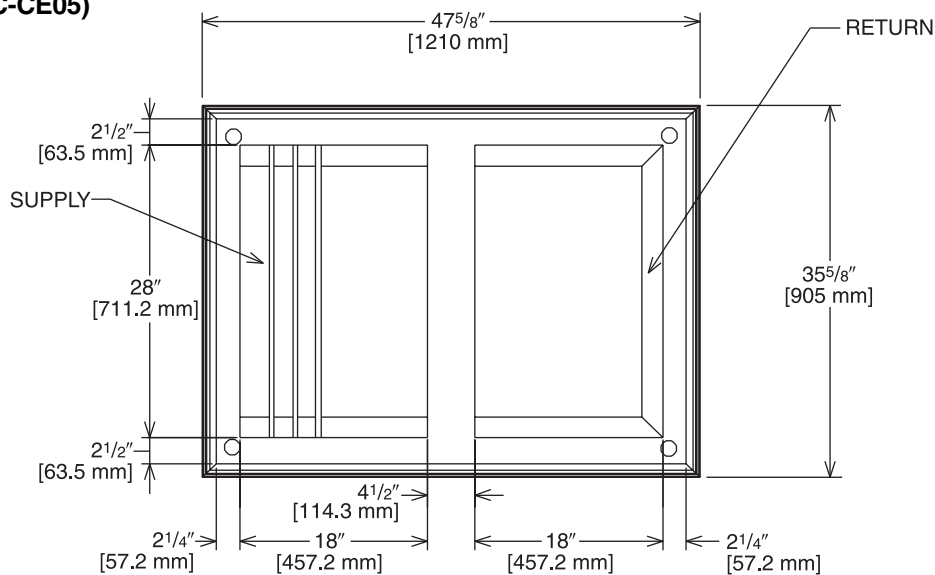

Illustration
ADS-7951-06A

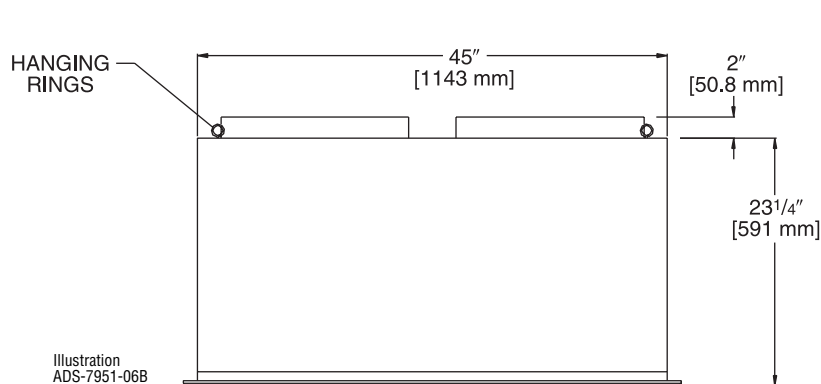

Illustration
ADS-7951-06B

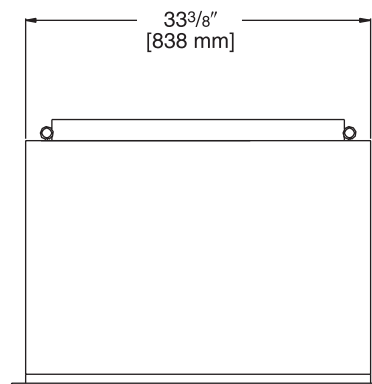

Illustration
ADS-7951-06C

ENGINEERING DATA^①

Model No.	Flow Rate CFM [L/s]	Static Pressure in w.c. [kPa]	Throw ^{② ③} Feet [m]	Neck Velocity fpm [m/s]	Noise Level ^④ (dbA)
RXRN-AA71	3600 [1699]	0.17 [0.042]	22-29 [6.7-8.8]	844 [4.3]	35
	3800 [1793]	0.18 [0.045]	22-30 [6.7-9.1]	891 [4.5]	40
	4000 [1888]	0.21 [0.052]	24-33 [7.3-10.1]	938 [4.8]	40
	4200 [1982]	0.24 [0.060]	26-35 [7.9-10.7]	985 [5.0]	40
	4400 [2076]	0.27 [0.067]	28-37 [8.5-11.3]	1032 [5.2]	40

NOTES: ① All data is based on the air diffusion council guidelines.

② Throw data is based on 75 FPM Terminal Velocities using isothermal air.

③ Throw is based on diffuser blades being directed in a straight pattern.

④ Actual noise levels may vary due to duct design and do not include transmitted unit noise.

Adequate duct attenuation must be provided to reduce sound output from the unit.

[] Designates Metric Conversions



Guide Specifications SKKL-B090, B120 and B151

Note about this specification: Copying this document directly into your building specification is permissible.

GAS HEAT PACKAGED ROOFTOP

HVAC Guide Specifications

Size Range: 7½ and 10 Nominal Tons

<u>Section</u>	<u>Description</u>
----------------	--------------------

23 06 80	Schedules for Decentralized HVAC Equipment
-----------------	---------------------------------------------------

23 06 80.13	Decentralized Unitary HVAC Equipment Schedule
--------------------	------------------------------------------------------

23 06 80.13.A.	Rooftop unit schedule
----------------	-----------------------

1. Schedule is per the project specification requirements.

23 07 16	HVAC Equipment Insulation
-----------------	----------------------------------

23 07 16.13	Decentralized, Rooftop Units:
--------------------	--------------------------------------

23 07 16.13.A.	Evaporator fan compartment:
----------------	-----------------------------

1. Interior cabinet surfaces shall be insulated with a minimum 3/4-in. thick, minimum 1-1/2 lb density, flexible fiberglass insulation bonded with foil face on the air side.
2. Insulation and adhesive shall meet NFPA 90A requirements for flame spread and smoke generation.
3. Insulation shall also be mechanically fastened with welded pin and retainer washer.

23 07 16.13.B.	Gas heat compartment:
----------------	-----------------------

1. Aluminum foil-faced fiberglass insulation shall be used.
2. Insulation and adhesive shall meet NFPA 90A requirements for flame spread and smoke generation.
3. Insulation shall also be mechanically fastened with welded pin and retainer washer.

23 09 13	Instrumentation and Control Devices for HVAC
-----------------	-----------------------------------------------------

23 09 13.23	Sensors and Transmitters:
--------------------	----------------------------------

23 09 13.23.A.	Thermostats
----------------	-------------

1. Thermostat must
 - a. energize both “W” and “G” when calling for heat.
 - b. have capability to energize 2 different stages of heating.
 - c. must include capability for occupancy scheduling.

23 09 33	Electric and Electronic Control System for HVAC
-----------------	--------------------------------------------------------

23 09 33.13	Decentralized, Rooftop Units:
--------------------	--------------------------------------

23 09 33.13.A.	General:
----------------	----------

1. Shall be complete with self-contained low-voltage control circuit protected by a fuse on the 24-V transformer side (B072-B150 units have a resettable circuit breaker).
2. Shall utilize color-coded wiring.
3. Unit shall include self-contained low-voltage control circuit protected by a fuse on the 24-V transformer side with a resettable circuit breaker.
4. The heat exchanger shall be controlled by an integrated furnace controller (IFC) microprocessor. See heat exchanger section of this specification.
5. Unit shall include a minimum of one 8-pin screw terminal connection board for connection of control wiring.

23 09 33.23.B.	Safeties:
----------------	-----------

1. Compressor over-temperature, over current.
2. Low-pressure switch.
 - a. Units shall have low pressure, loss of charge automatic reset device that will shut off compressor when tripped.
3. High-pressure switch.
 - a. Unit shall be equipped with high pressure switch manual reset device that will shut off compressor when tripped.
4. Automatic reset, motor thermal overload protector.
5. Heating section shall be provided with the following minimum protections:
 - a. High-temperature limit switches.
 - b. Induced draft motor pressure switch.
 - c. Flame rollout switch.
 - d. Flame proving controls.

23 09 33 Sequence of Operations for HVAC Controls

23 09 93.13 Decentralized, Rooftop Units:

23 09 93.13 INSERT SEQUENCE OF OPERATION

23 40 13 Panel Air Filters

23 40 13.13 Decentralized, Rooftop Units:

23 40 13.13.A. Standard filter section shall

1. Shall consist of factory-installed, low velocity, throwaway 2-in. thick fiberglass filters of commercially available sizes.
2. Unit shall use only one filter size. Multiple sizes are not acceptable.
3. Filter face velocity shall not exceed 365 fpm at nominal airflows.
4. Filters shall be accessible through an access panel with “no-tool” removal as described in the unit cabinet section of the specification (23 81 19.13.H).

23 81 19 Self-Contained Air Conditioners

23 81 19.13 (7.5, 10 and 12.5 Ton) Capacity Self-Contained Air Conditioners

23 81 19.13.A. General

1. Outdoor, rooftop mounted, electrically controlled, heating and cooling unit utilizing a(n) hermetic scroll compressor(s) for cooling duty and gas combustion for heating duty.
2. Factory assembled, single-piece heating and cooling rooftop unit. Contained within the unit enclosure shall be all factory wiring, piping, controls, and special features required prior to field start-up.
3. Unit shall use environmentally safe, R410A refrigerant.
4. Unit shall be installed in accordance with the manufacturer’s instructions.
5. Unit must be selected and installed in compliance with local, state, and federal codes.

23 81 19.13.B. Quality Assurance

1. Unit meets ASHRAE 90.1-2010 minimum efficiency requirements.
2. 3 phase units are Energy Star qualified.
3. Unit shall be rated in accordance with AHRI Standards 340/360.
4. Unit shall be designed to conform to ASHRAE 15, 2001.
5. Unit shall be UL-tested and certified in accordance with ANSI Z21.47 Standards and UL-listed and certified under Canadian standards as a total package for safety requirements.
6. Insulation and adhesive shall meet NFPA 90A requirements for flame spread and smoke generation.
7. Unit casing shall be capable of withstanding 1000-hour salt spray exposure per ASTM B117 (scribed specimen).
8. Unit casing shall be capable of withstanding Federal Test Method Standard No. 141 (Method 6061) 5000-hour salt spray.
9. Unit shall be designed in accordance with ISO 9001:2000, and shall be manufactured in a facility registered by ISO 9001:2000.
10. Roof curb shall be designed to conform to NRCA Standards.
11. Unit shall be subjected to a completely automated run test on the assembly line. The data for each unit will be stored at the factory, and must be available upon request.
12. Unit shall be constructed to prevent intrusion of snow and tested to prevent snow intrusion into the control box up to 40 mph.
13. Unit shake tested to assurance level 1, ASTM D4169 to ensure shipping reliability.

23 81 19.13.C. Delivery, Storage, and Handling

1. Unit shall be stored and handled per manufacturer’s recommendations.
2. Lifted by crane requires either shipping top panel or spreader bars.
3. Unit shall only be stored or positioned in the upright position.

23 81 19.13.E. Project Conditions

1. As specified in the contract.

23 81 19.13.F. Operating Characteristics

1. Unit shall be capable of starting and running at 115°F (46°C) ambient outdoor temperature, meeting maximum load criteria of AHRI Standard 340/360 at ± 10% voltage.
2. Compressor with standard controls shall be capable of operation down to 50°F (10°C), ambient outdoor temperatures. Low ambient accessory kit is necessary if mechanically cooling at ambient temperatures to 0°F (-17.7°C).
3. Unit shall discharge supply air vertically or horizontally as shown on contract drawings.
4. Unit shall be factory configured for vertical supply & return configurations.
5. Unit shall be field convertible from vertical to horizontal configuration.
6. Unit shall be capable of mixed operation: vertical supply with horizontal return or horizontal supply with vertical return.

23 81 19.13.G. Electrical Requirements

1. Main power supply voltage, phase, and frequency must match those required by the manufacturer.

23 81 19.13.H. Unit Cabinet

1. Unit cabinet shall be constructed of galvanized steel.
2. Unit cabinet exterior paint shall be: powder coat paint.
3. Evaporator fan compartment interior cabinet insulation shall conform to AHRI Standards 210 or 360 minimum exterior sweat criteria. Interior surfaces shall be insulated with a minimum 3/4-in. thick, 1-1/2 lb density, flexible fiberglass insulation, foil faced on the air side. Aluminum foil-faced fiberglass insulation shall be used in the gas heat compartment.
4. Base of unit shall have a location for thru-the-base gas and electrical connections standard.
5. Base Rail
 - a. Unit shall have base rails on a minimum of 4 sides.
 - b. Holes shall be provided in the base rails for rigging shackles to facilitate maneuvering and overhead rigging.
 - c. Holes shall be provided in the base rail for moving the rooftop for fork truck.
 - d. Base rail shall be a minimum of 14 gauge thickness.
6. Condensate pan and connections:
 - a. Shall be a sloped condensate drain pan made of a non-corrosive material and be removable for cleaning.
 - b. Shall comply with ASHRAE Standard 62.
 - c. Shall use a 1" - 2 NPT drain connection, possible either through the bottom or side of the drain pan. Connection shall be made per manufacturer's recommendations.
 - d. Shall be able to be easily removed.
7. Top panel:
 - a. Shall be a single piece top panel over indoor section.
8. Gas Connections:
 - a. All gas piping connecting to unit gas valve shall enter the unit cabinet at a single location on side of unit (horizontal plane).
 - b. Thru-the-base capability
 - i. Standard unit shall have a thru-the-base gas-line location using a continuous raised, flange around opening in the basepan.
 - ii. No basepan penetration, other than those authorized by the manufacturer, is permitted.
9. Electrical Connections
 - a. All unit power wiring shall enter unit cabinet a a single, factory-prepared, continuous raised flange opening in the basepan.
 - b. Thru-the-base capability
 - i. Standard unit shall have a thru-the-base electrical location(s) using a raised, continuous raised flange opening in the basepan.
 - ii. No basepan penetration, other than those authorized by the manufacturer, is permitted.
10. Component access panels (standard)
 - a. Cabinet panels shall be easily opened for servicing.
 - b. Panels covering control box, indoor fan, indoor fan motor, gas components (where applicable), and filters shall have hinges with 1/4 turn fasteners.
 - c. 1/4 fasteners shall be permanently attached.

23 81 19.13.I. Gas Heat

1. General
 - a. Heat exchanger shall be an induced draft design. Positive pressure heat exchanger designs shall not be allowed.
 - b. Shall incorporate a direct-spark ignition system and redundant main gas valve.
 - c. Heat exchanger design shall allow combustion process condensate to gravity drain; maintenance to drain the gas heat exchanger shall not be required.
 - d. Gas supply pressure at the inlet to the rooftop unit gas valve must match that required by the manufacturer.
2. The heat exchanger shall be controlled by an integrated furnace controller (IFC) microcompressor.
 - a. IFC board shall notify users of fault using and LED (light-emitting diode).
 - b. The Light Emitting Diode (LED) shall be visible without opening the control box access panel.

3. Standard Heat Exchanger construction
 - a. Heat exchanger shall be of the tubular-section type constructed of a minimum of 20-gauge steel coated with a nominal 1.2 mil aluminum-silicone alloy for corrosion resistance.
 - b. Burners shall be of the in-shot type constructed of aluminum-coated steel.
 - c. Burners shall incorporate orifices for rated heat output up to 2000 ft (610m) elevation. Additional accessory kits may be required for applications above 2000 ft (610m) elevation, depending on local gas supply conditions.
 - d. Each heat exchanger tube shall contain tubulators for increased heating effectiveness.
4. Optional Stainless Steel Heat Exchanger construction
 - a. Use energy saving, direct-spark ignition system.
 - b. Use a redundant main gas valve.
 - c. Burners shall be of the in-shot type constructed of aluminum-coated steel.
 - d. All gas piping shall enter the unit cabinet at a single location on side of unit (horizontal plane).
 - e. The optional stainless steel heat exchanger shall be of the tubular-section type, constructed of a minimum of 20-gauge type 409 stainless steel.
 - f. Type 409 stainless steel shall be used in heat exchanger tubes.
 - g. Complete stainless steel heat exchanger allows for greater application flexibility.
5. Induced draft combustion motor and blower
 - a. Shall be a direct-drive, single inlet, forward-curved centrifugal type.
 - b. Shall be made from steel with a corrosion-resistant finish.
 - c. Shall be permanently lubricated sealed bearings.
 - d. Shall have inherent thermal overload protection.
 - e. Shall have an automatic reset feature.

23 81 19.13.J. Coils

1. Standard Aluminum/Copper Coils:
 - a. Standard evaporator coils shall be aluminum lanced plate fins mechanically bonded to seamless internally grooved copper tubes with all joints brazed.
 - b. Evaporator and condenser coils shall be leak tested to 150 psig, pressure tested to 400 psig, and qualified to UL 1995 burst test at 2,200 psi.
 - c. Micro coils. Condenser coil shall be aluminum MicroChannel coils.

23 81 19.13.K. Refrigerant Components

1. Refrigerant circuit shall include the following control, safety, and maintenance features:
 - a. Shall use orifice refrigerant control (7.5 & 10 ton).
 - b. Shall use TXV Refrigerant control (12.5 ton)
 - c. Refrigerant filter drier.
 - d. Service gauge connections on suction and discharge lines.
 - e. External pressure gauge ports access shall be located in front exterior of cabinet.
2. Compressors
 - a. Unit shall use one fully hermetic, scroll compressor for each independent refrigeration circuit.
 - b. Compressor motors shall be cooled by refrigerant gas passing through motor windings.
 - c. Compressors shall be internally protected from high discharge temperature conditions.
 - d. Compressors shall be protected from an over-temperature and over-amperage conditions by an internal, motor overload device.
 - e. Compressor shall be factory mounted on rubber grommets.
 - f. Compressor motors shall have internal line break thermal and current overload protection.
 - g. Crankcase heaters shall not be required for normal operating range.
 - h. Compressor shall have molded electrical plug.

23 81 19.13.L. Filter Section

1. Filters access is specified in the unit cabinet section of this specification.
2. Filters shall be held in place by filter tray, facilitating easy removal and installation.
3. Shall consist of factory-installed, low velocity, throw-away 2-in. thick fiberglass filters.
4. Filter face velocity shall not exceed 320 fpm at nominal airflows.
5. Filters shall be standard, commercially available sizes.
6. Only one size filter per unit is allowed.



23 81 19.13.M. Evaporator Fan and Motor

1. Evaporator fan motor:
 - a. Shall have permanently lubricated bearings
 - b. Shall have inherent automatic-reset thermal overload protection.
 - c. Shall have a maximum continuous bhp rating for continuous duty operation; no safety factors above that rating shall be required.
2. Belt-driven Evaporator Fan:
 - a. Belt drive shall include an adjustable-pitch motor pulley.
 - b. Shall use sealed, permanently lubricated ball-bearing type.
 - c. Blower fan shall be double-inlet type with forward-curved blades.
 - d. Shall be constructed from steel with a corrosion resistant finish and dynamically balanced.

23 81 19.13.N. Condenser Fans and Motors

1. Condenser fan motors:
 - a. Shall be a totally enclosed motor.
 - b. Shall use permanently lubricated bearings.
 - c. Shall have inherent thermal overload protection with an automatic reset feature.
 - d. Shall use a shaft-down design. Shaft-up designs including those with “rain-slinger devices” shall not be allowed.
2. Condenser Fans shall:
 - a. Shall be a direct-driven propeller type fan
 - b. Shall have aluminum blades riveted to corrosion-resistant steel spiders and shall be dynamically balanced.

23 81 19.13.O. Special Features

1. Integrated Economizers:
 - a. Integrated, gear-driven parallel modulating blade design type capable of simultaneous economizer and compressor operation.
 - b. Independent modules for vertical or horizontal return configurations shall be available. Vertical return modules shall be available as a factory installed option.
 - c. Damper blades shall be galvanized steel with metal gears. Plastic or composite blades on intake or return shall not be acceptable.
 - d. Shall include all hardware and controls to provide free cooling with outdoor air when temperature and/or humidity are below setpoints.
 - e. Shall be equipped with gear driven dampers for both the outdoor ventilation air and the return air for positive air stream control.
 - f. Shall be equipped with low-leakage dampers, not to exceed 2% leakage at 1 in. wg pressure differential.
 - g. Shall be capable of introducing up to 100% outdoor air.
 - h. Shall be equipped with a barometric relief damper capable of relieving up to 100% return air.
 - i. Shall be designed to close damper(s) during loss-of-power situations with spring return built into motor.
 - j. Enthalpy sensor shall be provided as standard. Outdoor air sensor set point shall be adjustable and shall range from 40 to 100°F / 4 to 38°C. Additional sensor options shall be available as accessories.
 - k. The economizer controller shall also provide control of an accessory power exhaust unit function. Factory set at 70%, with a range of 0% to 100%.
 - l. The economizer shall maintain minimum airflow into the building during occupied period and provide design ventilation rate for full occupancy. A remote potentiometer may be used to override the damper set point.
 - m. Dampers shall be completely closed when the unit is in the unoccupied mode.
 - n. Economizer controller shall accept a 2-10Vdc CO₂ sensor input for IAQ/DCV control. In this mode, dampers shall modulate the outdoor-air damper to provide ventilation based on the sensor input.
 - o. Actuator shall be direct coupled to economizer gear. No linkage arms or control rods shall be acceptable.
 - p. Economizer controller shall provide indications when in free cooling mode, in the DCV mode, or the exhaust fan contact is closed.
 - q. Economizer wire harness will have provision for smoke detector.
2. Manual damper
 - a. Manual damper package shall consist of damper, air inlet screen, and rain hood which can be preset to admit up to 50% outdoor air for year round ventilation.

3. Liquid Propane (LP) Conversion Kit
 - a. Package shall contain all the necessary hardware and instructions to convert a standard natural gas unit for use with liquefied propane, up to 2000 ft (610m) elevation.
4. Flue Shield
 - a. Flue shield shall provide protection from the hot sides of the gas flue hood.
5. Condenser Coil Hail Guard Assembly
 - a. Shall protect against damage from hail.
 - b. Shall be louvered style.
6. Unit-Mounted, Non-Fused Disconnect Switch:
 - a. Switch shall be factory-installed, internally mounted.
 - b. National Electric Code (NEC) and UL approved non-fused switch shall provide unit power shutoff.
 - c. Shall be accessible from outside the unit.
 - d. Shall provide local shutdown and lockout capability.
7. Convenience Outlet:
 - a. Powered convenience outlet.
 - b. Outlet shall be powered from main line power to the rooftop unit.
 - c. Outlet shall be powered from line side or load side of disconnect by installing contractor, as required by code. If outlet is powered from load side of disconnect, unit electrical ratings shall be UL certified and rated for additional outlet amperage.
 - d. Outlet shall be factory-installed and internally mounted with easily accessible 115-v female receptacle.
 - e. Outlet shall include 15 amp GFI receptacles with independent fuse protection.
 - f. Voltage required to operate convenience outlet shall be provided by a factory-installed step-down transformer.
 - g. Outlet shall be accessible from outside the unit.
 - h. Non-Powered convenience outlet.
 - i. Outlet shall be powered from a separate 115-120v power source.
 - j. A transformer shall not be included.
 - k. Outlet shall be field-installed and internally mounted with easily accessible 115-v female receptacle.
 - l. Outlet shall include 15 amp GFI receptacle with independent fuse protection.
 - m. Outlet shall be accessible from outside the unit.
8. Flue Discharge Deflector:
 - a. Flue discharge deflector shall direct unit exhaust vertically instead of horizontally.
 - b. Deflector shall be defined as a “natural draft” device by the National Fuel and Gas (NFG) code.
9. Propeller Power Exhaust:
 - a. Power exhaust shall be used in conjunction with an integrated economizer.
 - b. Independent modules for vertical or horizontal return configurations shall be available.
 - c. Horizontal power exhaust is shall be mounted in return ductwork.
 - d. Power exhaust shall be controlled by economizer controller operation. Exhaust fans shall be energized when dampers open past the 0-100% adjustable setpoint on the economizer control.
10. Roof Curbs (Vertical):
 - a. Formed galvanized steel with wood nailer strip and shall be capable of supporting entire unit weight.
 - b. Permits installation and securing of ductwork to curb prior to mounting unit on the curb.
11. Universal Gas Conversion Kit:
 - a. Package shall contain all the necessary hardware and instructions to convert a standard natural gas unit to operate from 2000-7000 ft (610 to 2134m) elevation with natural gas or from 0-7000 ft (90-2134m) elevation with liquefied propane.
12. Return Air Enthalpy Sensor:
 - a. The return air enthalpy sensor shall be used in conjunction with an outdoor air enthalpy sensor to provide differential enthalpy control.
13. Indoor Air Quality (CO₂) Sensor:
 - a. Shall be able to provide demand ventilation indoor air quality (IAQ) control.
 - b. The IAQ sensor shall be available in duct mount, wall mount, or wall mount with LED display. The set point shall have adjustment capability.



14. Smoke detectors:
 - a. Shall be a Four-Wire Controller and Detector.
 - b. Shall be environmental compensated with differential sensing for reliable, stable, and drift-free sensitivity.
 - c. Shall use magnet-activated test/reset sensor switches.
 - d. Shall have tool-less connection terminal access.
 - e. Shall have a recessed momentary switch for testing and resetting the detector.
 - f. Controller shall include:
 - i. One set of normally open alarm initiation contacts for connection to an initiating device circuit on a fire alarm control panel
 - ii. Two Form-C auxiliary alarm relays for interface with rooftop unit or other equipment
 - iii. One Form-C supervision (trouble) relay to control the operation of the Trouble LED on a remote test/reset station
 - iv. Capable of direct connection to two individual detector modules.
 - v. Can be wired to up to 14 other duct smoke detectors for multiple fan shutdown applications.
15. Barometric relief
 - a. Shall include damper, seals, hard-ware, and hoods to relieve excess building pressure.
 - b. Damper shall gravity-close upon shutdown.
16. Time Guard
 - a. Shall prevent compressor short cycling by providing a 5-minute delay (± 2 minutes) before restarting a compressor after shutdown for any reason.
 - b. One device shall be required per compressor.

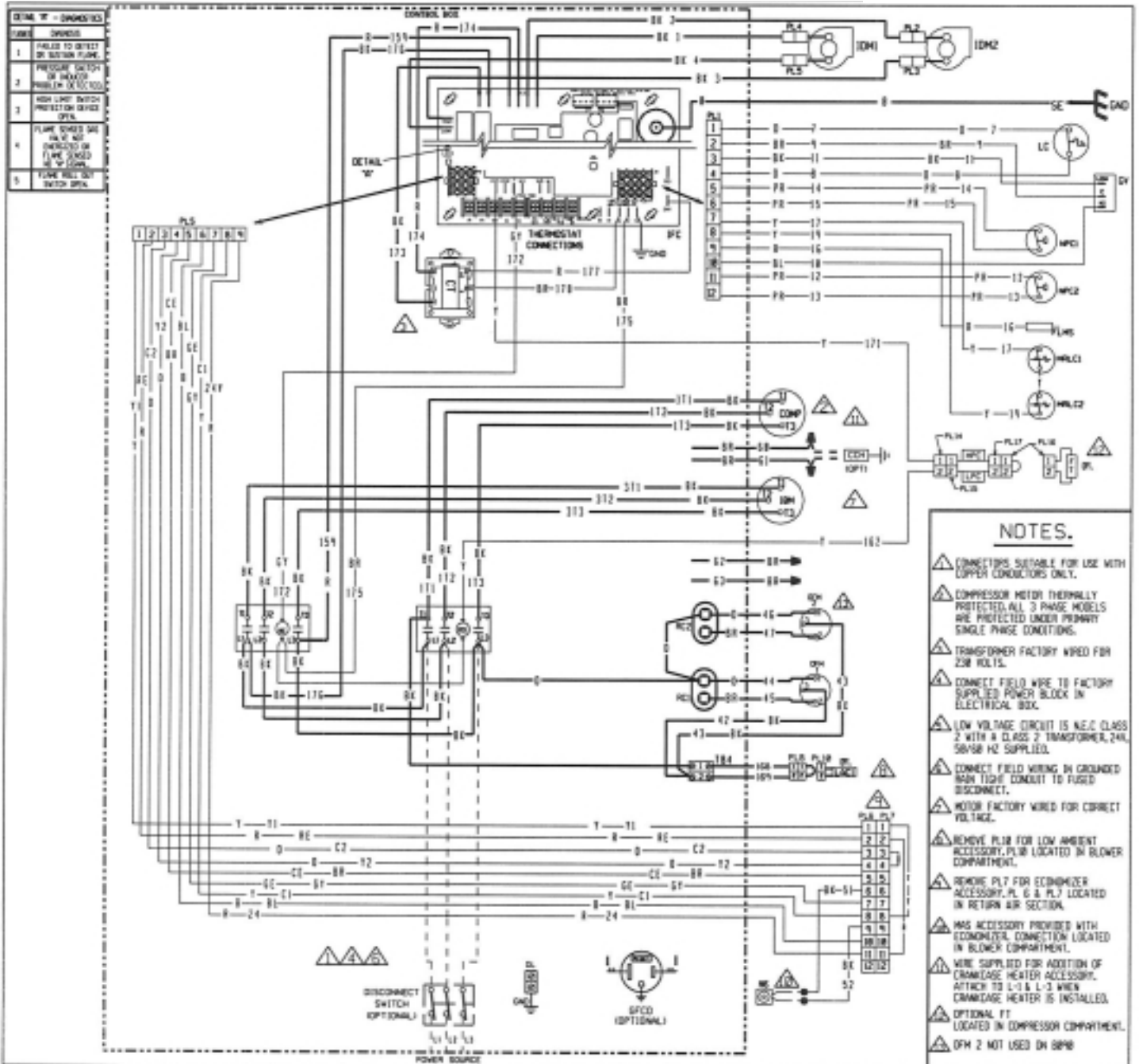

DETAIL 'W'	SYMBOL
1	FAULTS TO DETECT ON BLOWER FUSE.
2	PRELIMINARY SWITCH OF HEATER PROTECTION OF SECTION.
3	HIGH LIMIT SWITCH PROTECTION DEVICE OPEN.
4	FLAME SENSORS ARE NOT INSTALLED OR (LINE SENSORS ARE NOT INSTALLED).
5	LOW VOLTAGE SWITCH OPEN.

- NOTES.**
- ⚠ CONNECTORS SUITABLE FOR USE WITH COPPER CONDUCTORS ONLY.
 - ⚠ COMPRESSOR MOTOR THERMALLY PROTECTED. ALL 3 PHASE MODELS ARE PROTECTED UNDER PRIMARY SINGLE PHASE CONDITIONS.
 - ⚠ TRANSFORMER FACTORY WIRING FOR 230 VOLTS.
 - ⚠ CONNECT FIELD WIRE TO FACTORY SUPPLIED POWER BLOCK IN ELECTRICAL BOX.
 - ⚠ LOW VOLTAGE CIRCUIT IS N.E.C. CLASS 2 WITH A CLASS 2 TRANSFORMER, 24V, 50/50 W2 SUPPLIED.
 - ⚠ CONNECT FIELD WIRING IN GROUNDED RAIN TIGHT CONDUIT TO FUSED DISCONNECT.
 - ⚠ MOTOR FACTORY WIRING FOR CORRECT VOLTAGE.
 - ⚠ REMOVE PL18 FOR LOW AMBIENT ACCESSORY. PL18 LOCATED IN BLOWER COMPARTMENT.
 - ⚠ REMOVE PL7 FOR ECONOMIZER ACCESSORY. PL 6 & PL7 LOCATED IN RETURN AIR SECTION.
 - ⚠ HAS ACCESSORY PROVIDED WITH ECONOMIZER CONNECTION LOCATED IN BLOWER COMPARTMENT.
 - ⚠ WIRE SUPPLIED FOR ADDITION OF CRANKCASE HEATER ACCESSORY. ATTACH TO L-1 & L-3 WHEN CRANKCASE HEATER IS INSTALLED.
 - ⚠ OPTIONAL FT LOCATED IN COMPRESSOR COMPARTMENT.
 - ⚠ OPH 2 NOT USED ON 8890.

COMPONENT CODE	
BC	BLOWER CONTACTOR
CC	COMPRESSOR CONTACTOR
CH	CRANKCASE HEATER
COMP	COMPRESSOR
CT	CONTROL TRANSFORMER
DISC	DISCONNECT SWITCH
FLMS	FLAME SENSOR
FT	FREEZE STAT
GFCO	GROUND FAULT CONVENIENCE OUTLET
GL	GROUND LUG
GRS	GROUND
GY	GAS VALVE
HPC	HIGH PRESSURE CONTROL
ISM	INDUCED DRAFT MOTOR BELT DRIVE
ISM	INDUCED DRAFT MOTOR
IFC	INTEGRATED FURNACE CONTROL
LAC	LOW AMBIENT COOLING CONTROL
IFC	INTEGRATED FURNACE CONTROL
LAC	LOW AMBIENT COOLING CONTROL
LC	LIMIT CONTROL
LPC	LOW PRESSURE CONTROL
MAS	MIX AIR SENSOR
MRLC	MANUAL RESET LIMIT CONTROL
NPC	NEGATIVE PRESSURE CONTROL
OPH	OUTDOOR FAN MOTOR
PL	PLUG
RC	RUN CAPACITOR
SE	SEMI CONDUCTOR
TS	TERMINAL BLOCK
W	WIRE NUT

WIRING INFORMATION

LINE VOLTAGE
 -FACTORY STANDARD
 -FACTORY OPTION
 -FIELD INSTALLED

LOW VOLTAGE
 -FACTORY STANDARD
 -FACTORY OPTION
 -FIELD INSTALLED

REPLACEMENT WIRE
 -MUST BE THE SAME SIZE AND TYPE OF INSULATION AS ORIGINAL (85°C MIN.)

WARNING
 -CABINET MUST BE PERMANENTLY GROUNDED AND CONFORM TO I.E.C., N.E.C., C.E.C., AND LOCAL CODES AS APPLICABLE.

WIRE COLOR CODE			
BK	BLACK	O	ORANGE
BR	BROWN	PR	PURPLE
BL	BLUE	R	RED
G	GREEN	W	WHITE
GY	GRAY	Y	YELLOW

WIRING DIAGRAM
 (-)KKL-B090/120
 208-230/460V 3 PH, 60 HZ.
 208-220/380-415V, 3 PH, 50 HZ

DR. BY	CHK. BY	DATE	DWG. NO.	REV.
JRJ	SK	3-31-80	90-102890-05	02

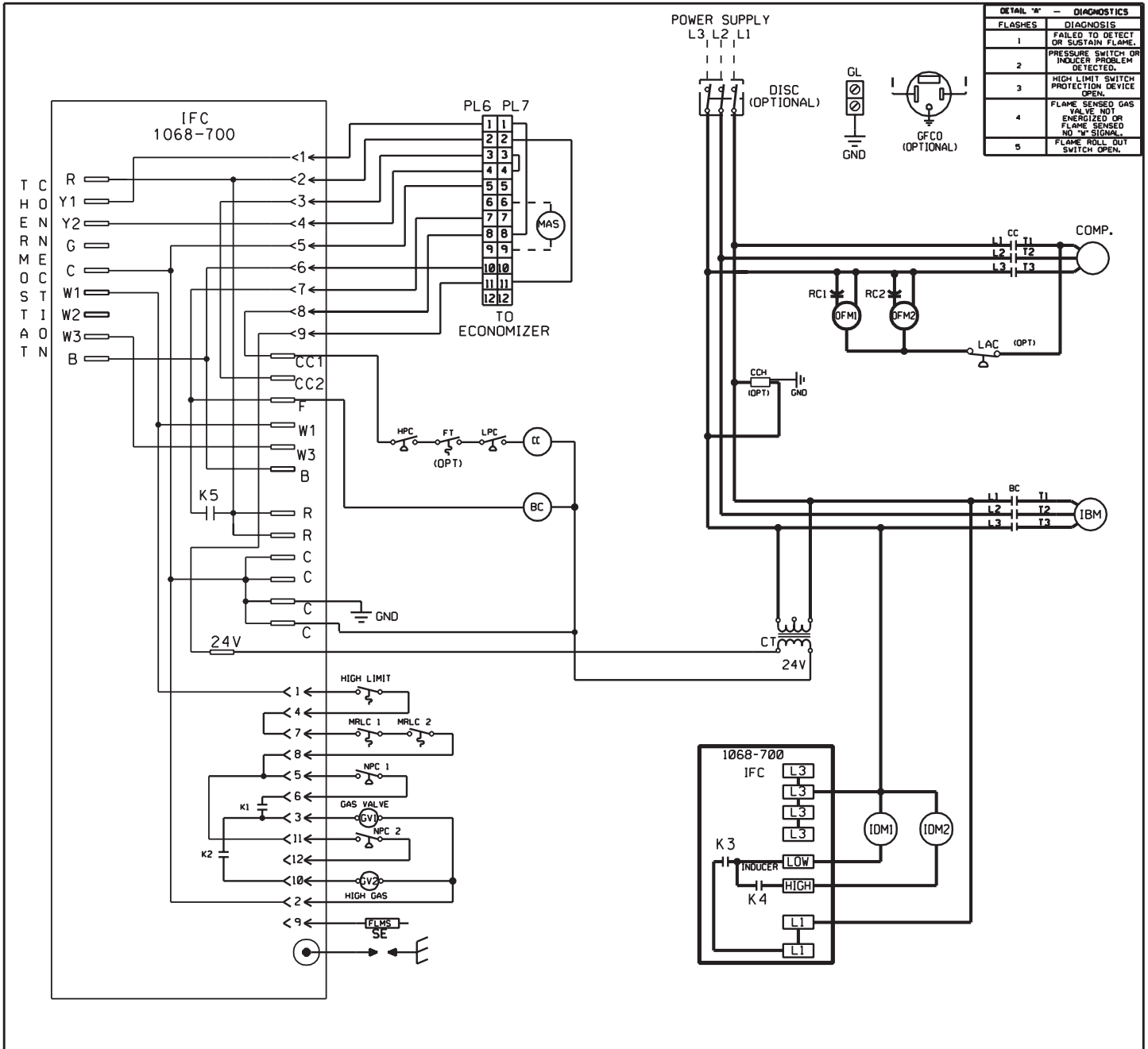

FLASHES	DIAGNOSIS
1	FAILED TO DETECT OR SUSTAIN FLAME.
2	PRESSURE SWITCH OR INDUCER PROBLEM DETECTED.
3	HIGH LIMIT SWITCH PROTECTION DEVICE OPEN.
4	FLAME SENSED GAS VALVE NOT ENERGIZED OR FLAME SENSED NO "F" SIGNAL.
5	FLAME ROLL OUT SWITCH OPEN.

THERMOSTATION

COMPONENT CODE

- | | |
|--------------------------------------|---------------------------------|
| BC BLOWER CONTACTOR | IDM INDUCED DRAFT MOTOR |
| CC COMPRESSOR CONTACTOR | IFC INTEGRATED FURNACE CONTROL |
| CCH CRANKCASE HEATER | LC LIMIT CONTROL |
| COMP COMPRESSOR | LPC LOW PRESSURE CONTROL |
| CT CONTROL TRANSFORMER | MAS MIX AIR SENSOR |
| DISC DISCONNECT SWITCH | MRLC MANUAL RESET LIMIT CONTROL |
| FLMS FLAME SENSOR | NPC NEGATIVE PRESSURE CONTROL |
| FT FREEZE STAT | OFM OUTDOOR FAN MOTOR |
| GFCO GROUND FAULT CONVENIENCE OUTLET | PL PLUG |
| GL GROUND LUG | RC RUN CAPACITOR |
| GND GROUND | SE SPARK ELECTRODE |
| GV GAS VALVE | TB TERMINAL BLOCK |
| HPC HIGH PRESSURE CONTROL | |
| IBM INDOOR BLOWER MOTOR BELT DRIVE | |

WIRING INFORMATION

- LINE VOLTAGE
 -FACTORY STANDARD _____
 -FACTORY OPTION - - - - -
 -FIELD INSTALLED - - - - -
- LOW VOLTAGE
 -FACTORY STANDARD _____
 -FACTORY OPTION - - - - -
 -FIELD INSTALLED - - - - -
- REPLACEMENT WIRE
 -MUST BE THE SAME SIZE AND TYPE OF INSULATION AS ORIGINAL (105° C MIN.)
- WARNING
 -CABINET MUST BE PERMANENTLY GROUNDED AND CONFORM TO I.E.C., N.E.C., C.E.C., AND LOCAL CODES AS APPLICABLE.

WIRE COLOR CODE

- | | |
|----------|-----------|
| BK BLACK | O ORANGE |
| BR BROWN | PR PURPLE |
| BL BLUE | R RED |
| G GREEN | W WHITE |
| GY GRAY | Y YELLOW |

WIRING SCHEMATIC
 (-)KKL-B090/120
 208-230/460V, 3 PH, 60 HZ.
 200-220/380-415V, 3 PH, 50 HZ

DR. BY	APP. BY	DATE	DWG. NO.	REV
JRJ		3-31-10	90-102891-05	00

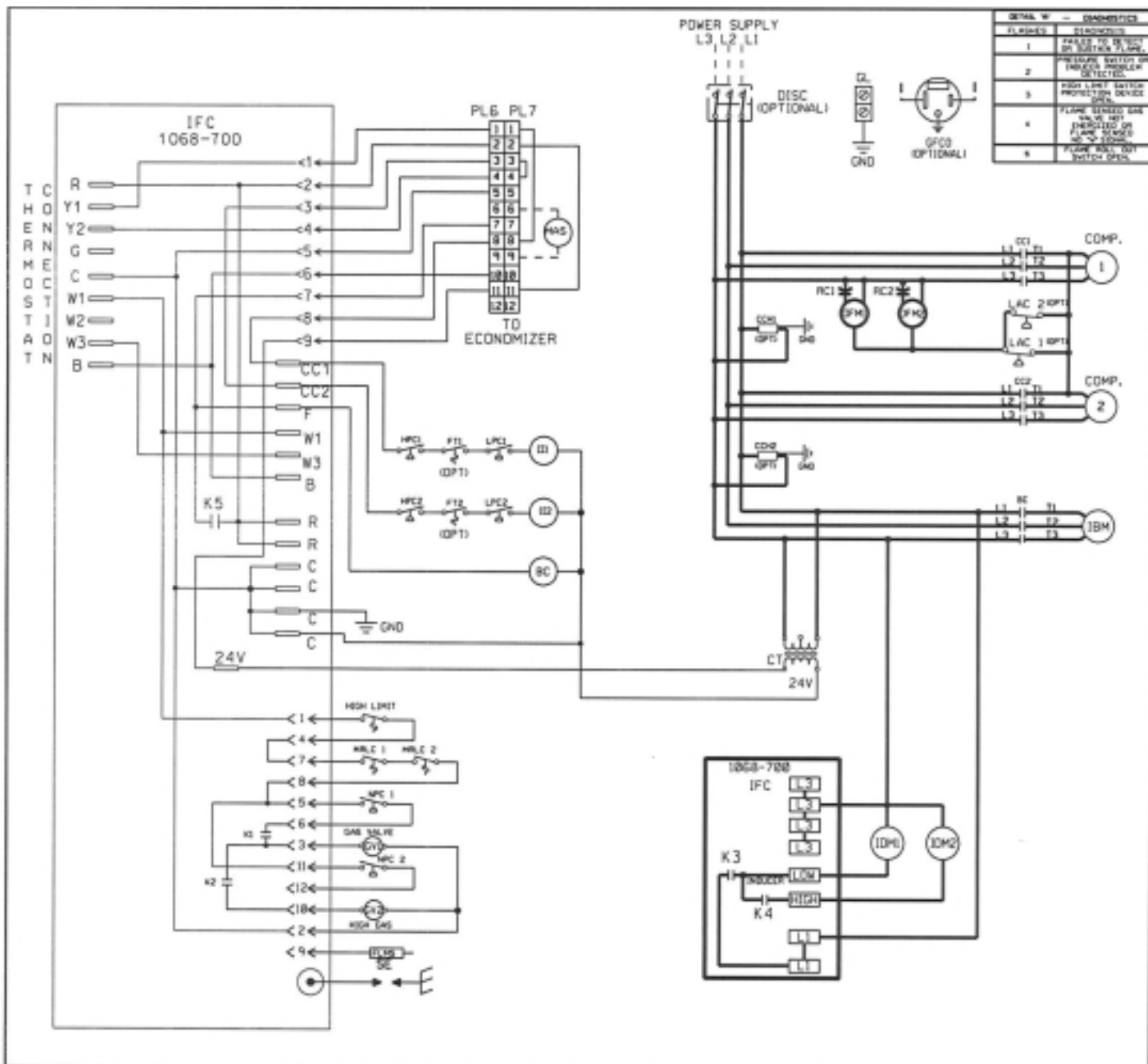

COMPONENT CODE		WIRING INFORMATION	WIRE COLOR CODE
BC	BLOWER CONTACTOR	LINE VOLTAGE	BK BLACK
CC	COMPRESSOR CONTACTOR	-FACTORY STANDARD	BR BROWN
COH	CRANKCASE HEATER	-FACTORY OPTION	BL BLUE
COMP	COMPRESSOR	-FIELD INSTALLED	G GREEN
CT	CONTROL TRANSFORMER	LOW VOLTAGE	GY GRAY
DISC	DISCONNECT SWITCH	-FACTORY STANDARD	D ORANGE
FLMS	FLAME SENSOR	-FACTORY OPTION	PR PURPLE
FT	FREEZE STAT	-FIELD INSTALLED	R RED
GFCO	GROUND FAULT CONVENIENCE OUTLET	REPLACEMENT WIRE	W WHITE
G	GROUND LUG	-MUST BE THE SAME SIZE AND TYPE OF INSULATION AS ORIGINAL (95°C MIN.)	Y YELLOW
GND	GROUND	WARNING	
GV	GAS VALVE	-CABINET MUST BE PERMANENTLY GROUNDED AND CONFORM TO I.E.C., N.E.C., C.E.C., AND LOCAL CODES AS APPLICABLE.	
HPC	HIGH PRESSURE CONTROL		
IBM	INDOOR BLOWER MOTOR BELT DRIVE		
IFC	INTEGRATED FURNACE CONTROL		
LC	LIMIT CONTROL		
LPC	LOW PRESSURE CONTROL		
MAG	MIX AIR SENSOR		
MRLC	MANUAL RESET LIMIT CONTROL		
NPC	NEGATIVE PRESSURE CONTROL		
DFM	OUTDOOR FAN MOTOR		
PL	PLUS		
PT	POWER TRANSFORMER		
RC	RUN CAPACITOR		
SE	SPARK ELECTRODE		
TB	TERMINAL BLOCK		

WIRING SCHEMATIC
 (-)KNL-8090/102/120/150/151
 208-238/460V, 3 PH, 60 HZ.
 208-228/380-415V, 3 PH, 50 HZ

DR. BY: MGR DATE: 9-22-88 DWG. NO.: 98-102691-01 REV: 03

Before proceeding with installation, refer to installation instructions packaged with each model, as well as complying with all Federal, State, Provincial, and Local codes, regulations, and practices.

**Rheem Heating,
Cooling and
Water Heating**

P.O. Box 17010, Fort Smith, AR 72917



"In keeping with its policy of continuous progress and product improvement, Rheem reserves the right to make changes without notice."